

MAX-8

V2211.01



EP
Let's grow together

MAX-8

Excellent Performances & Reliability

CPCD15-18T8

T8 series 1.5-1.8t forklift

EP EQUIPMENT CO.,LTD

www.ep-eq.eu

CPCD15/18T8

T8 series 1.5-1.8t forklift specification

		EP		
		CPCD15T8-SAQ 2	CPCD15T8-NB485BPG	CPCD18T8-SAQ2
General	1 Manufacture			
	2 Model			
	3 Power type		Diesel	Diesel
	4 Rated capacity	Kg	1500	1500
	5 Load center	mm	500	500
	6 Lift height	mm	3000	3000
	7 Free lift height	mm	120	120
Characteristics & Dimensions	8 Fork size	L×W×T	920×100×40	920×100×40
	9 Mast tilt range	F/R	6/12	6/12
	10 Fork overhang(wheel center to fork face)	mm	420	420
	11 Rear overhang	mm	420	420
	12 Length to face of fork	mm	2270	2320
	13 Overall width	mm	1080	1080
	14 Mast lowered height	mm	1995	1995
	15 Mast extended height	mm	3960	3960
	16 Overhead guard height	mm	2070	2070
	17 Turning radius(outside)	mm	1995	2035
Performance	18 Min.tight angle stacking aisle width (Add load length and clearance)	mm	2400	2440
	19 Travel (No load)	Km/h	14	14
	20 Speed	mm/sec	460	460
	21 Lowering (Full load)	mm/sec	450	450
	22 Max. Drawbar Pull (Full load)	N	14300	14800
	23 Max. Gradeability (Full load)	%	20	20
	24 Tyres	mm	6.50-10-10PR	6.50-10-10PR
	25	mm	5.00-8-10PR	5.00-8-10PR
	26 Tread	mm	920	920
	27	mm	920	920
Chassis	28 Wheelbase	mm	1430	1430
	29 Ground clearance	mm	110	110
	30 Wheelbase center	mm	140	140
	31 Self weight	Kg	2700	2900
	32	Kg	3570	3995
Weight	33 Weight	mm	630	705
	34 Distribution	mm	1215	1305
	35	mm	1485	1595
	36 Battery	V/AH	12/60	12/60
	37	V/AH	S4Q2	S4Q2
Power & transmission	38	Modal	NB485BPG	NB485BPG
	39	Manufacture	XIN CHAI	XIN CHAI
	40 Rated output/r.p.m	kw	32.9/2500	32.9/2500
	41 Rated torque/r.p.m	N.m	135/2000	135/2000
	42 No. of cylinder	4	4	4
	43 Bore×Stroke	mm	88×103	88×103
	44 Displacement	cc	2505	2505
	45 Fuel tank capacity	L	50	50
	46 Transmissions	Type	OEM	OEM
	47	Stage	Powershift	Powershift
48 Operating pressure	Mpa	1/1	1/1	

1.Special lifting height available (2-stage mast :2.5m,2.7m,3.0m,3.3m,3.6m,3.7m,4m,4.3m,4.5m,5m. Full Free Duplex Mast 3.0m,3.3m,3.5m,3.6m, 3-stage mast : 4.3m,4.5m,4.8m,5m,5.5m,6m)
 2.Attachment available. 3. The specification in the table are for standard models only,For further information please contact us. 4.Specification are subject to change without notice.

1.5~1.8t T8 series mast: (pneumatic)

Type	Model	Max. fork height	Overall height				Free lift		Front Overhang		Tilt range		Capacity			
			Lowered	Extended		Without backrest	With backrest	1.5t	1.8t	FWD	BWD	Load capacity at 500 mm				
				Without backrest	With backrest							Single tire		Double tire		
												1.5t	1.8t	1.5t	1.8t	
Wide view mast	2W200	2000	1495	2585	2955	120	120	420	420	6	12	1500	1800	1500	1800	
	2W250	2500	1745	3085	3455	120	120	420	420	6	12	1500	1800	1500	1800	
	2W270	2700	1845	3285	3655	120	120	420	420	6	12	1500	1800	1500	1800	
	2W300	3000	1995	3585	3955	120	120	420	420	6	12	1500	1800	1500	1800	
	2W330	3300	2145	3885	4255	120	120	420	420	6	12	1500	1800	1500	1800	
	2W350	3500	2245	4085	4455	120	120	420	420	6	12	1500	1800	1500	1800	
	2W360	3600	2295	4185	4555	120	120	420	420	6	12	1500	1800	1500	1800	
	2W400	4000	2545	4585	4955	120	120	420	420	6	12	1400	1700	1500	1800	
	2W430	4300	2695	4885	5255	120	120	420	420	6	6	1300	1600	1400	1700	
2W450	4500	2795	5085	5455	120	120	420	420	6	6	1250	1500	1350	1600		
wide view full 2-stage mast	2F250	2500	1790	3105	3455	1045	765	420	420	6	12	1500	1800	1500	1800	
	2F270	2700	1890	3305	3655	1145	865	420	420	6	12	1500	1800	1500	1800	
	2F300	3000	2040	3605	3955	1345	1105	420	420	6	12	1500	1800	1500	1800	
	2F330	3300	2190	3905	4255	1495	1165	420	420	6	12	1500	1800	1500	1800	
	2F360	3600	2340	4205	4555	1645	1315	420	420	6	12	1500	1800	1500	1800	
	2F400	4000	2540	4605	4955	1815	1565	420	420	6	12	1400	1700	1500	1800	
wide view full 3-stage mast	3F430	4300	1965	5070	5255	1425	1080	440	440	6	6	1250	1500	1350	1600	
	3F450	4500	2045	5130	5465	1485	1140	440	440	6	6	1200	1400	1300	1500	
	3F480	4800	2160	5445	5755	1575	1230	440	440	6	6	1100	1300	1200	1400	
	3F500	5000	2210	5605	5955	1665	1320	440	440	6	6	1050	1200	1150	1300	
	3F550	5500	2375	6120	6455	1825	1480	440	440	3	6	/	/	950	1100	
	3F600	6000	2600	6695	6955	1975	1630	440	440	3	6	/	/	750	900	

Note:1. With sideshifter minus 150Kg, with integral sideshifter minus 100Kg.

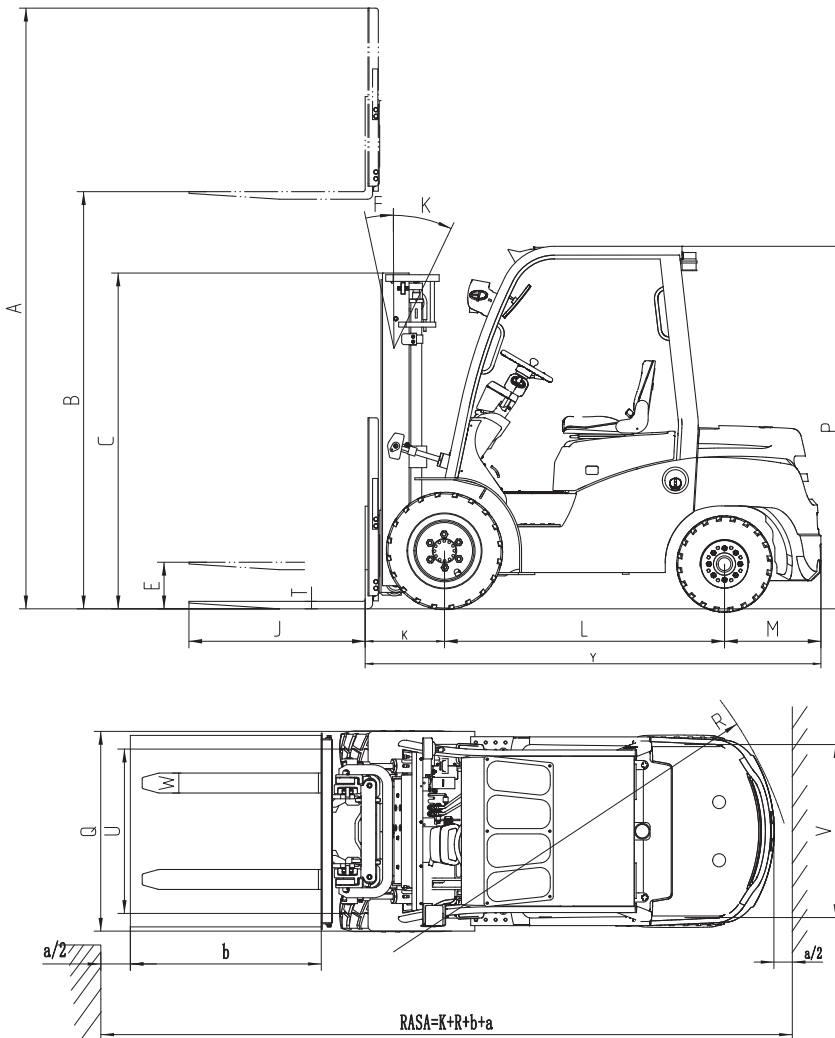

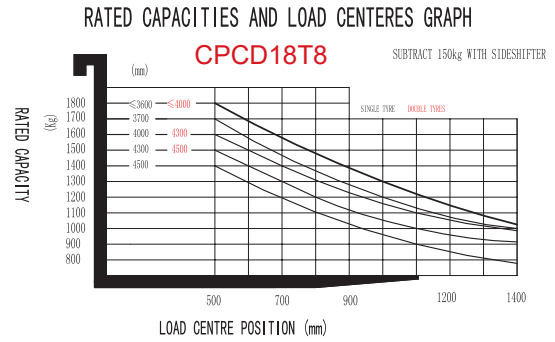
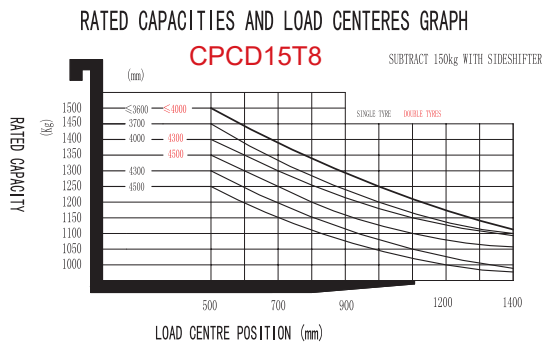

Option

Options		15/18T8
1	Fork length	○
2	Fork extension	○
3	Folded fork	○
4	Imported diesel engine	○
5	Import Gasoline Engine	○
6	LPG system	○
7	High exhaust	○
8	Dual air clearners or special air cleaner	○
9	Solid rubber tire	○
10	No marking solid tire	○
11	Overhead guard	●
12	Mast options	○
13	Attachments	○
14	Integrated side shift	○
15	Cockpit	●
16	heater	○
17	Front windshield with wiper	○
18	Rear windshield with wiper	○
19	Fan	○
20	Full steel cabin room	○
21	LED front light	●
22	Rear working LED light	○
23	Fire extinguisher	○
24	Suspension seat	○
25	Seat switch	●
26	Warning light	●
27	Insulation mat	○
28	Double front tyre	○
29	OPS system	○

Note: ● standard ○ option — NA

WAELLER sp. z o.o. sp. k.

PL 83-034 Trąbki Wielkie, ul. Towarowa 1 • PL 80-457 Gdańsk, ul. Powstańców Wielkopolskich 11

Tel. (+48) 58 683 01 53, 58 691 27 15, 784 046 763, 601 642 339

biuro@ep-eq.pl • www.ep-eq.pl