



CPD15/20L1

Electric Counterbalance Forklift
Truck 1.5/2.0T **LI-ION**
TECHNOLOGY

- High efficiency with high performance;
- IPX4 Rated, Suitable for Outdoor Usage;
- Standard Lithium battery, fast charging and convenient using;
- High comfort for operation with larger cab;

EP EQUIPMENT CO.,LTD
www.ep-eq.eu



Electric Counterbalance Forklift Truck 1.5/2.0T

CPD15/20L1

Distinguishing mark	1.1	Manufacturer			EP	EP
	1.2	Model designation			CPD15L1	CPD20L1
	1.3	Drive			Electric	Electric
	1.4	Operator type			Seated	Seated
	1.5	Load capacity	Q	kg	1500	2000
	1.6	Load center distance	c	mm	500	500
	1.8	Load distance, centre of drive axle to fork	x	mm	405	405
	1.9	Wheelbase	y	mm	1470	1470
	Service weight	2.1	Service weight		kg	2640
2.2		Axle loading, laden front/rear		kg	3615/525	4380/570
2.3		Axle loading, unladen front/rear		kg	1190/1450	1155/1795
Tyres/chassis	3.1	Tyre type			Solid rubber	Solid rubber
	3.2	Tyre size, front			18X7-8	200/50-10
	3.3	Tyre size, rear			5.00-8	5.00-8
	3.5	Wheels, number front/rear (x=drive wheels)		mm	2x/ 2	2x/ 2
	3.6	Tread width, front	b10	mm	910	910
	3.7	Tread width, rear	b11	mm	920	920
Dimensions	4.1	Tilt of mast/fork carriage forward/backward	α/β	°	6/ 11	6/ 11
	4.2	Retracted mast height	h1	mm	1990	1990
	4.3	Free lift	h2	mm	105	105
	4.4	Lift height	h3	mm	3000	3000
	4.5	Height, mast extended	h4	mm	4028	4028
	4.7	Height of overhead guard (cabin)	h6	mm	2080	2080
	4.8	Seat height/standing height	h7	mm	1050	1050
	4.12	Tow coupling height	h10	mm	360	360
	4.19	Overall length	l1	mm	3270	3270
	4.20	Length to face of forks	l2	mm	2200	2200
	4.21	Overall width	b1/b2	mm	1080	1080
	4.22	Fork dimensions	s/e/l	mm	40×100×1070	40×122×1070
	4.23	A,B Fork carriage class/type A, B			2A	2A
	4.24	Fork carriage width	b3	mm	1040	1040
	4.31	Ground clearance, laden, below mast	m1	mm	110	110
	4.32	Ground clearance, center of wheelbase	m2	mm	105	105
	4.34.1	Aisle width for pallets 1000×1200 crossways	Ast	mm	3685	3685
4.34.2	Aisle width for pallets 800×1200 crossways	Ast	mm	3885	3885	
4.35	Turning radius	Wa	mm	2080	2080	
Performance data	5.1	Travel speed, laden/unladen		km/h	10.5/14	10.5/14
	5.2	Lifting speed, laden/unladen		m/s	0.3/ 0.42	0.28/ 0.42
	5.3	Lowering speed, laden/unladen		m/s	0.42/ 0.45	0.43/ 0.45
	5.5	Drawbar pull, laden/unladen		N	—	—
	5.6	Max. drawbar pull, laden/unladen		N	—	10000
	5.8	Max. gradeability, laden/unladen		%	10.5/14	10.5/14
	5.10	Service brake			Electromagnetic	Electromagnetic
5.11	Parking brake			Electromagnetic	Electromagnetic	
Electric-engine	6.1	Drive motor rating S2 60 min		kW	6	6
	6.2	Lift motor rating at S3 15%		kW	7.5	7.5
	6.4	Battery voltage/nominal capacity		V/Ah	48V405AH	48V405AH
	6.5	Battery weight		kg	260	260
Addition data	8.1	Type of drive control			AC	AC
	10.5	Steering design			Hydraulic	Hydraulic
	10.7	Sound pressure level at the driver's ear		dB(A)	70	70

If there are improvements of technical parameters or configurations, no further notice will be given.
The diagram shown may contain non-standard configurations.

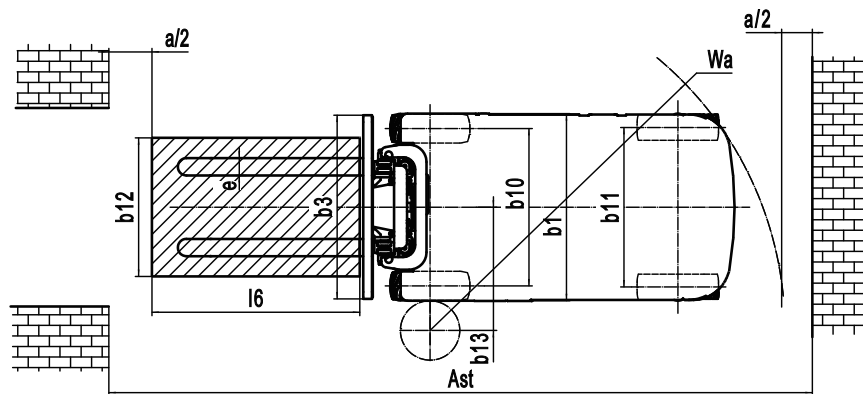
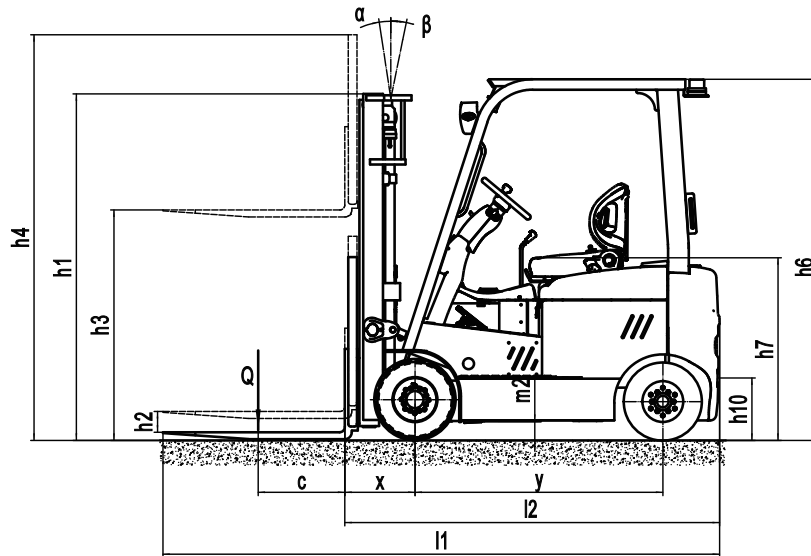

Mast Option

Mast types	Lift height (h3)	Height, Mast			Height, Free lift(h2)	
		Height, mast lowered(h1)	Height, mast extended(h4)		No shelving	With shelving
			No shelving	With shelving		
		mm	mm	mm	mm	mm
2-Standard Mast	2700	1840	3185	3728	105	105
	3000	1990	3485	4028	105	105
	3300	2140	3785	4328	105	105
	3600	2290	4085	4628	105	105
2-Free Mast	3000	2023	3485	4028	1538	995
	3300	2173	3785	4328	1688	1145
	3600	2323	4085	4628	1838	1295
3-Free Mast	4000	1845	4485	5028	1360	817
	4350	1995	4844	5378	1501	967
	4500	2045	4994	5528	1551	1017
	4800	2145	5294	5828	1651	1117
	5000	2210	5494	6028	1716	1182

RATED CAPACITIES AND LOAD CENTERES GRAPH

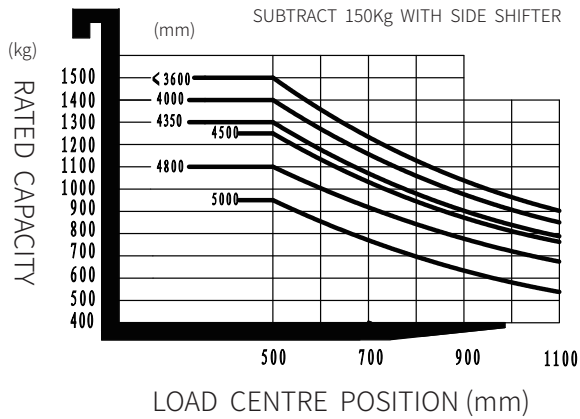

RATED CAPACITIES AND LOAD CENTERES GRAPH

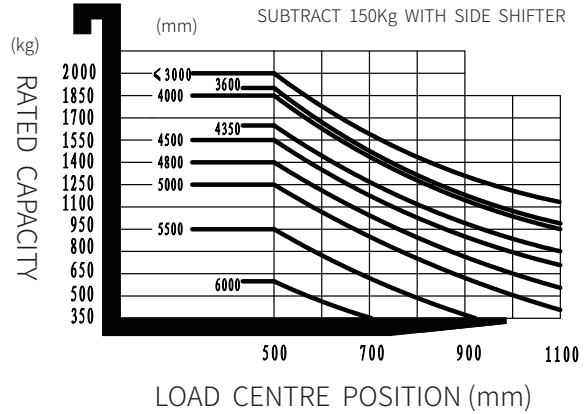

Option

No.	Optional items	CPD15L1/20L1
1.1	Fork dimension	○122*40*920○122*40*1070○122*40*1150○122*40*1220○122*40*1370 ○122*40*150○122*40*1600○122*40*1700○122*40*1820
1.4	Fork carriage width	●1040mm○Yes and can be customized
1.5	Fork carriage height	●1010mm○Yes and can be customized
2.5	Front wheel material	●Solid○Non-marking solid
2.6	Rear wheel material	●Solid○Non-marking solid
2.7	Battery capacity	●48V405AH
2.8	Charger	○48V100A○48V150A○48V200A
2.9	Battery indicator	●With time
2.10	Seat type	●Premium○Suspension○Suspension+Seatbelt logic switch
2.11	Attachments	●No○Built-in sidershifter○External shifter○Fork positioner
2.13	Traction pin	●Yes
2.14	Electrostatic chain	●Yes
3.1	Foldable fork	●No○Yes and can be customized
3.5	Front lamp	●LED
3.6	Rear lamp	●No○LED
3.7	Warning lamp	●Yes
3.8	Steering lamp	●Yes
3.9	Blue lamp	●No○2 front○1 rear○2 front + 1 rear
3.10	Area warning lamp	●No○Red, 1 left + 1 right
3.11	Rearview mirror	●1 rearview mirror○Add one on both sides
3.12	Buzzer	●Yes
3.17	OPS system	●No○Yes and can be customized
3.19	USB interface	●Yes
3.23	Telematics	●No○Yes and can be customized
4.1	Battery side pull function	●No○Yes and can be customized
4.3	Cabin	●No○Basic semi-enclosed cabin○Upgrade semi-enclosed cabin○Full cabin
4.9	Heater	●No○Yes and can be customized

Note: ● standard ○ option — NA

WAELLER sp. z o.o. sp. k.

PL 83-034 Trąbki Wielkie, ul. Towarowa 1 • PL 80-457 Gdańsk, ul. Powstańców Wielkopolskich 11

Tel. (+48) 58 683 01 53, 58 691 27 15, 784 046 763, 601 642 339

biuro@ep-eq.pl • www.ep-eq.pl