



# CQD15S

## Electric Stand-up Reach Truck 1.5t

- Best Choice for Stacking in Narrow Aisles & High Racking;
- Stand-on Operation Provides Broader View;
- Electric Power Steering Control, Comfortable and Efficient;
- None-floating drive system, solid stable in high position

**EP EQUIPMENT CO.,LTD**

[www.ep-eq.eu](http://www.ep-eq.eu)

# Electric Reach Truck 1.5t CQD15S

Distinguishing mark	1.1	Manufacturer			EP
	1.2	Model designation			CQD15S
	1.3	Drive unit			Electric
	1.4	Operator type			Standing
	1.5	Rated capacity	Q	kg	1500
	1.6	Load center distance	c	mm	600
	1.8	Load distance, centre of drive axle to fork	x	mm	500 <sup>③</sup>
	1.9	Wheelbase	y	mm	1504
	Service weight	2.1	Service weight		kg
2.3.1		Axle loading, unladen front/rear		kg	1621/846
2.4.1		Axle loading, fork advanced, laden front/rear		kg	490/3445
2.5.1		Axle loading, fork retracted, laden front/rear		kg	1510/2416
Tyres/chassis	3.1	Tyre type			Polyurethane
	3.2.1	Tyre size, front		mm	Φ260×105
	3.3.1	Tyre size, rear		mm	Φ254×114
	3.4	Additional wheels		mm	Φ178×73
	3.5.1	Wheels, number front/rear (x=drive wheels)		mm	1x/2
	3.6	Tread, front	b10	mm	700
	3.7	Tread, rear	b11	mm	974
Dimensions	4.1	Tilt of mast/fork carriage forward/backward	α/β	°	2/4
	4.2	Height, mast lowered	h1	mm	2050 <sup>②</sup>
	4.3	Free lift	h2	mm	0 <sup>②</sup>
	4.4	Lift height	h3	mm	3000 <sup>②</sup>
	4.5	Height, mast extended	h4	mm	3860 <sup>②</sup>
	4.7	Height of overhead/ guard cabin	h6	mm	2255
	4.8	Seat height/standing height	h7	mm	335
	4.10	Height of wheel arms	h8	mm	280
	4.19	Overall length	l1	mm	2335 <sup>③</sup>
	4.20	Length to face of forks	l2	mm	1265 <sup>③</sup>
	4.21	Overall width	b1/b2	mm	1078/1090
	4.22	Fork dimensions	s/e/l	mm	40/100/1070
	4.23	A,B Fork carriage class/type A, B			2A
	4.24	Fork carriage width	b3	mm	830
	4.25	Distance between fork-arms	b5	mm	200-620
	4.26	Distance between wheel arms/loading surfaces	b4	mm	750
	4.28	Reach distance	l4	mm	665 <sup>③</sup>
	4.31	Ground clearance, laden, below mast	m1	mm	70
	4.32	Ground clearance, center of wheelbase	m2	mm	70
	4.34.1	Aisle width for pallets 1000×1200 crossways	Ast	mm	2745 <sup>③</sup>
4.34.2	Aisle width for pallets 800×1200 crossways	Ast	mm	2770 <sup>③</sup>	
4.35	Turning radius	Wa	mm	1765	
4.37	Length across wheel arms	l7	mm	1912	
Performance data	5.1	Travel speed, laden/unladen		km/h	8.5/9
	5.2	Lifting speed, laden/unladen		m/s	0.28/0.44
	5.3	Lowering speed, laden/unladen		m/s	0.52/0.48
	5.4	Reaching speed, laden /unladen		m/s	0.1/0.1
	5.8	Max. gradeability, laden/unladen		%	8/10
	5.10	Service brake			Electromagnetic
5.11	Parking brake			Electromagnetic	
Electric-engine	6.1	Drive motor rating S2 60 min		kW	4
	6.2	Lift motor rating at S3 15%		kW	8.2
	6.4	Battery voltage/nominal capacity		V/Ah	48/420
	6.5	Battery weight		kg	739
Addition data	8.1	Type of drive unit			AC
	10.5	Steering design			Electronic
	10.7	Sound pressure level at the driver's ear		dB(A)	75

If there are improvements of technical parameters or configurations, no further notice will be given.  
The diagram shown may contain non-standard configurations.

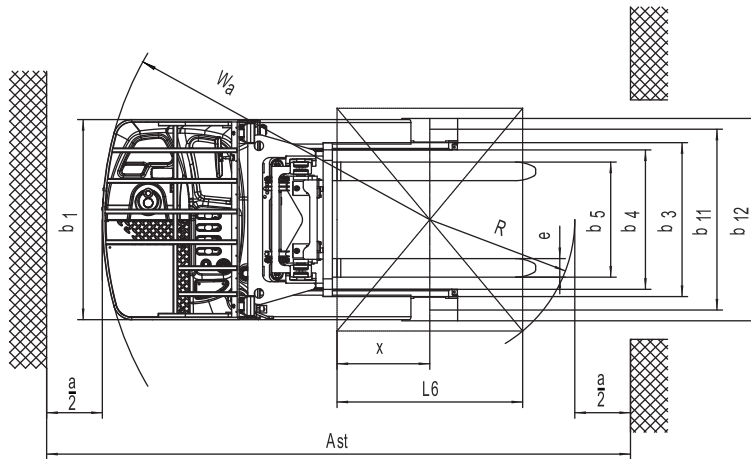
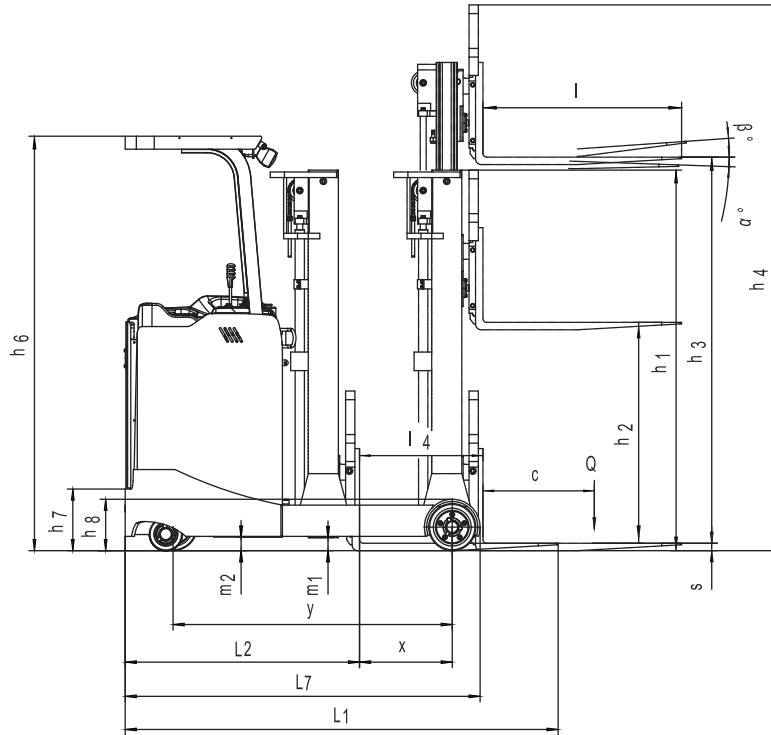

### RATED CAPACITIES GRAPH

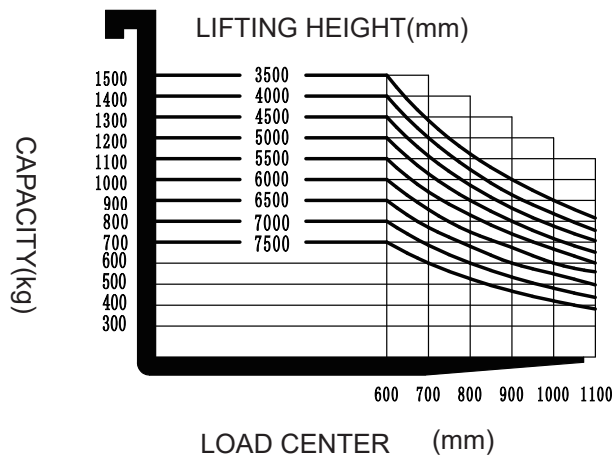

# Mast Option

## ①Service weight (include battery)

Mast height (mm)	Service weight (kg)
2-stage mast	
2700	2345
3000	2370
3300	2395
3640	2420
4000	2445
4300	2470
3-stage mast	
4000	2510
4500	2540
5000	2570
5500	2600
6000	2630
6500	2660
7000	2650
7500	2680

## ②Mast

Mast types	Lift height (h3)	Height, Mast			Height, Free lift(h2)	
		Height, mast lowered(h1)	Height, mast extended(h4)		No backrest	With backrest
			No backrest	With backrest		
	mm	mm	mm	mm	mm	mm
2-Standard Mast	2700	1900	3266	3560	0	0
	3000	2050	3566	3860	0	0
	3300	2200	3866	4160	0	0
	3640	2370	4206	4500	0	0
	4000	2550	4566	4860	0	0
	4300	2700	4866	5160	0	0
3-Free Mast	4000	1930	4700	4860	1060	1060
	4500	2100	5200	5360	1240	1240
	5000	2270	5700	5860	1400	1400
	5500	2440	6200	6360	1580	1580
	6000	2610	6700	6860	1740	1740
	6500	2780	7200	7360	1920	1920
	7000	2950	7700	7860	2080	2080
7500	3120	8200	8360	2260	2260	

## ③Dimensions(mm)

		without side shift		with side shift	
		2-stage mast	3-stage mast	2-stage mast	3-stage mast
Overall length (minimum)	I1	2335	2357	2370	2392
Length to face of forks	I2	1265	1287	1300	1322
Reach distance	I4	665		630	
Aisle width for pallets 1000×1200 crossways	Ast	2745	2760	2763	2783
Aisle width for pallets 800×1200 lenthways	Ast	2770	2790	2801	2820
Aisle width for pallets 1000×1200 lenthways	Ast	2825	2843	2853	2872
Aisle width for pallets 800×1200 crossways	Ast	2635	2645	2651	2662

## ④Battery

Capacity(Ah)	Battery weight (kg)
300	600
345	560
360	620
420	739
450	739
465	739

# Option

No.	Optional items	CQD15S
1.1	Fork dimension	○900*600、2A、100*40*920●900*600、2A、100*40*1070 ○900*600、2A、100*40*1150○900*600、2A、100*40*1220 ○900*600、2A、100*40*1370
1.2	Leg width	●751
1.4	Fork carriage width	●620mm(Without sidershifter)○655mm(With sidershifter)
1.5	backrest height	●820mm(Without sidershifter)○995mm(With sidershifter)
2.1	Load wheel type	●Single
2.2	Load wheel material	●Polyurethane
2.3	Drive wheel material	●Polyurethane
2.7	Battery capacity	○300Ah●420Ah○450Ah○465Ah○260Ah-Li○360Ah-Li
2.8	Charger	●48V-60A External ○48V-50A External ○48V-45A External
2.11	Attachments	●No○Built-in sidershifter
3.4	Water auto-filling system	●No○Yes and not customized
3.5	Front lamp	●LED
3.6	Rear lamp	●No○LED
3.7	Warning lamp	●Yes and not customized
3.9	Blue lamp	●No○Yes and not customized
3.10	Area warning lamp	●No○Yes and not customized
3.11	Rearview mirror	●Yes and not customized
3.12	Buzzer	●No○Yes and not customized
3.14	Camera	●No○Yes and not customized
3.15	Fire extinguisher	●No○Yes and not customized
3.23	Telematics	●No○Yes and not customized
4.1	Battery side pull function	●No○Yes and not customized
4.2	Cold storage	●No○Yes and not customized
4.6	Forks tilt forward and backward	●Yes and not customized
4.7	Overhead guard	●Yes○Yes and can be customized(Drive-in)
5.1	Battery side pull attachment	●No○Side pull bracket

Note: ●Standard ○ Optional - Inconformity



**WAELLER sp. z o.o. sp. k.**

PL 83-034 Trąbki Wielkie, ul. Towarowa 1 • PL 80-457 Gdańsk, ul. Powstańców Wielkopolskich 11  
Tel. (+48) 58 683 01 53, 58 691 27 15, 784 046 763, 601 642 339

biuro@ep-eq.pl • www.ep-eq.pl