



# EFX251

## Li-ion Pickup Forklift 2.5T

- PMSM technology for better efficiency and performance
- Unique Pickup design for driver convenience
- Bluetooth preventive service app for maintenance efficiency
- Operation safety and comfort assurance

**LI-ION**  
TECHNOLOGY

**EP EQUIPMENT CO.,LTD**  
[www.ep-eq.eu](http://www.ep-eq.eu)



## FEATURE

### ■ PMSM technology for better efficiency and performance

EFX251 adopts permanent magnet synchronous motor (PMSM) technology to deliver higher lifting power, longer bearing life. This efficiency optimization motor maximizes the battery uptime and brings better energy savings at optimal working scenarios by 10-15% comparing to regular motors.



10-15%  
Energy  
savings



30%  
Uptime  
improvement

### ■ Unique Pickup design for driver convenience

EFX251 features the pickup design and its open cargo area provides extra loading space for operators to carry additional cargo or personal belongings. Driver comfort goes beyond cozy seats.



### ■ Bluetooth preventive service app for maintenance efficiency

EFX251 makes maintenance easy with EP preventive service app that enables operators to connect the truck via bluetooth for parameter changes and monitoring as well as diagnostics trouble code reading without a handheld unit.



### ■ Operation safety and comfort assurance

EFX251 features its low center of gravity design, which protects the truck from rollover when turning. It offers better lateral stability for safety assurance. In addition, there is great noise reduction due to the motor being moved away from the operator.



# Li-ion Pickup Forklift 2.5T

## EFX251

Distinguishing mark	1.1	Manufacturer			EP
	1.2	Model designation			EFX251
	1.3	Drive unit			Electric
	1.4	Operator type			Seated
	1.5	rated capacity	Q	kg	2500
	1.6	Load center distance	c	mm	500
	1.8	Load distance, centre of drive axle to fork	x	mm	495
	1.9	Wheelbase	y	mm	1640
	Service weight	2.1	Service weight		kg
2.2		Axle loading, laden front/rear		kg	6105/485
2.3		Axle loading, unladen front/rear		kg	2110/1980
Tyres/chassis	3.1	Tyre type			Pneumatic
	3.2	Tyre size, front			28X9-15-14PR
	3.3	Tyre size, rear			6.50-10-10PR
	3.5	Wheels, number front/rear (x=drive wheels)		mm	2x/ 2
	3.6	Tread, front	b10	mm	970
	3.7	Tread, rear	b11	mm	980
	Dimensions	4.1	Tilt of mast/fork carriage forward/backward	$\alpha/\beta$	°
4.2		Height, mast lowered	h1	mm	2060
4.3		Free lift	h2	mm	120
4.4		Lift height	h3	mm	3000
4.5		Height, mast extended	h4	mm	4050
4.7		Height of overhead/ guard cabin	h6	mm	2170
4.8		Seat height/standing height	h7	mm	1100
4.12		Tow coupling height	h10	mm	480
4.19		Overall length	l1	mm	3619
4.20		Length to face of forks	l2	mm	2549
4.21		Overall width	b1/b2	mm	1154
4.22		Fork dimensions	s/e/l	mm	40×122×1070
4.23		A,B Fork carriage class/type A, B			2A
4.24		Fork carriage width	b3	mm	1150
4.31		Ground clearance, laden, below mast	m1	mm	100
4.32		Ground clearance, center of wheelbase	m2	mm	130
4.34.1		Aisle width for pallets 1000×1200 crossways	Ast	mm	4030
4.34.2		Aisle width for pallets 800×1200 crossways	Ast	mm	4230
4.35		turning radius	Wa	mm	2335
Performance data		5.1	Travel speed, laden/unladen		km/h
	5.2	Lifting speed, laden/unladen		m/s	0.27/0.36
	5.3	Lowering speed, laden/unladen		m/s	0.4/0.43
	5.5	Drawbar pull, laden/unladen		N	—
	5.6	Max. drawbar pull, laden/unladen		N	11000
	5.8	Max. gradeability, laden/unladen		%	15/15
	5.10	Service brake			Hydraulic
5.11	Parking brake			Mechanical	
Electric-engine	6.1	Drive motor rating S2 60 min		kW	8
	6.2	Lift motor rating at S3 15%		kW	16
	6.4	Battery voltage/nominal capacity		V/Ah	80/150
	6.5	Battery weight		kg	—
	Addition data	8.1	Type of drive unit		
10.5		Steering design			Hydraulic
10.7		ound pressure level at the driver's ear		dB(A)	< 74

If there are improvements of technical parameters or configurations, no further notice will be given.  
The diagram shown may contain non-standard configurations.

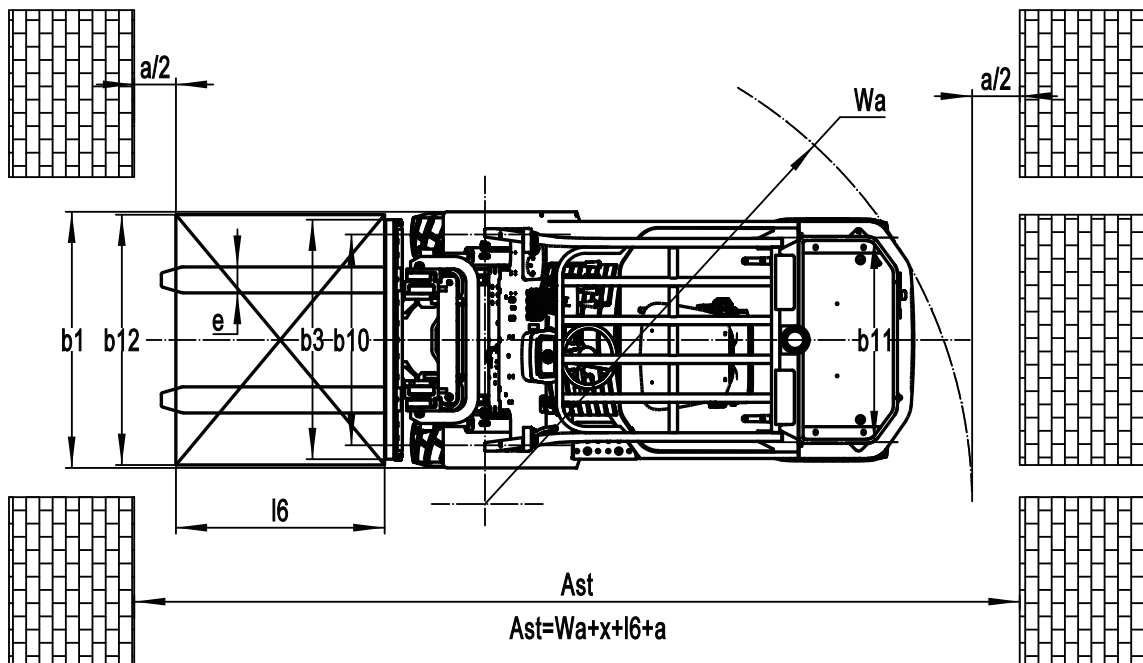
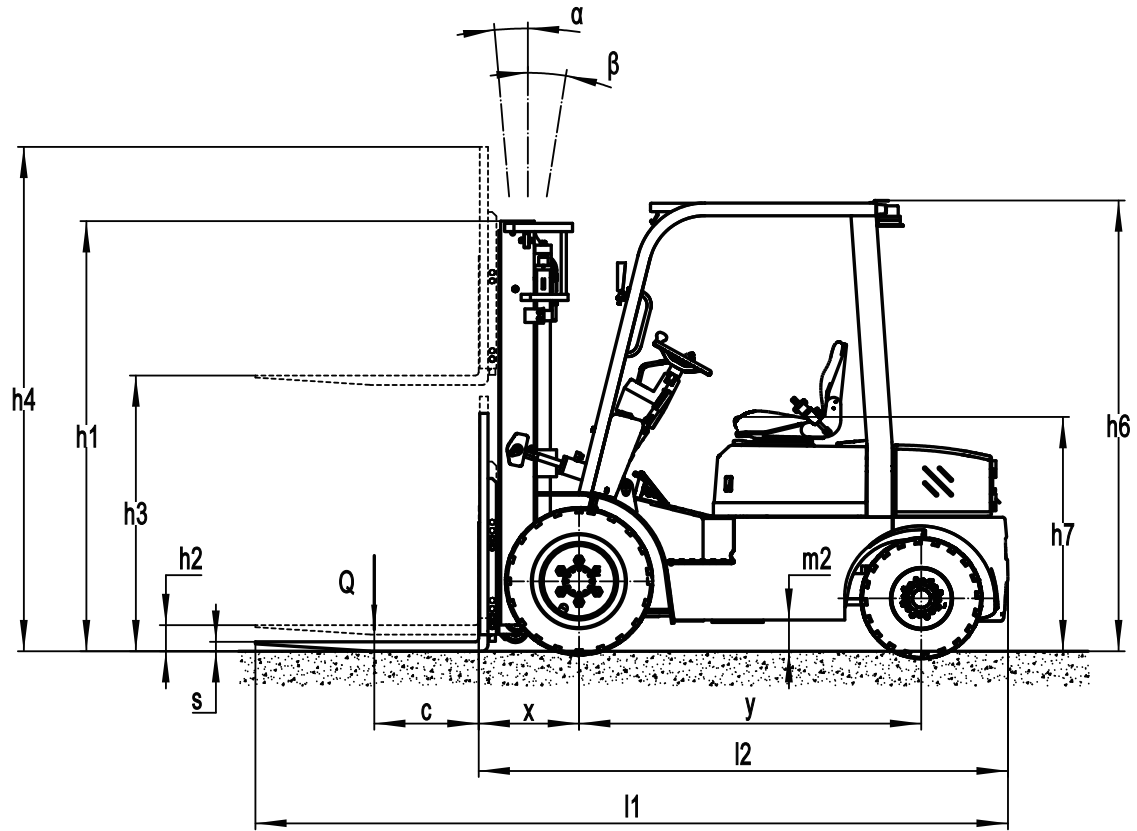

### RATED CAPACITIES AND LOAD CENTERS GRAPH

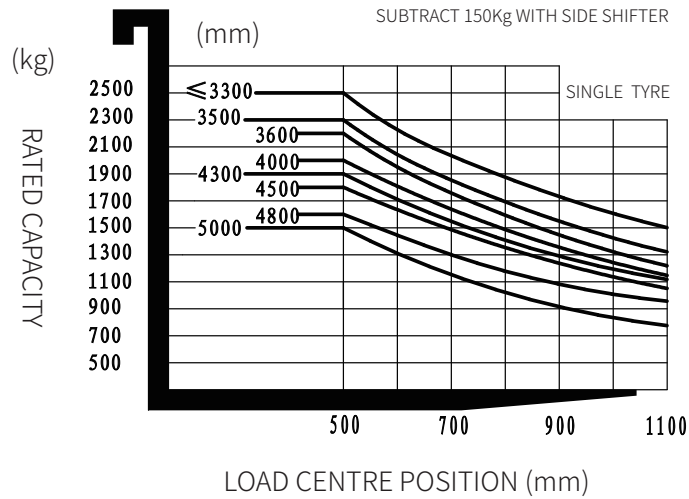

### Mast option:

Mast types	Lift height ( h3 )	Height, Mast			Height, Free lift(h2)	
		Height, mast lowered(h1)	Height, mast extended(h4)		No shelving	With shelving
			No shelving	With shelving		
	mm	mm	mm	mm	mm	mm
2-Standard Mast	2700	1925	3270	3810	120	120
	3000	2075	3570	4110	120	120
	3300	2225	3690	4410	120	120
	3500	2325	3890	4610	120	120
	3600	2375	3990	4710	120	120
	4000	2625	4040	5110	120	120
2-Free Mast	3000	2035	2620	4110	1460	810
	3300	2185	3870	4410	1610	960
	3600	2335	4020	4710	1760	1110
3-Free Mast	4300	2035	4910	5410	1360	730
	4500	2115	5070	5610	1460	810
	4800	2220	5375	5910	1565	915
	5000	2305	5570	6110	1610	960
	5500	2555	6065	6525	1990	1520

## Option:

No.	Optional items	EFX251
1.1	Fork dimension	●122*40*1070○122*40*1150○122*40*1220○122*40*1370 ○122*40*1500○122*40*1600○122*40*1700○122*40*1820
1.4	Fork carriage width	●1040mm○Yes and can be customized
1.5	Fork carriage height	●1025mm○Yes and can be customized
2.5	Front wheel material	●Pneumatic○Solid○Non-marking
2.6	Rear wheel material	●Pneumatic○Solid○Non-marking
2.7	Battery capacity	●80V 150AH
2.8	Charger	●80V35A (Integrated 1-phase) ○80V60A (Integrated 3-phase)
2.9	Battery indicator	●With time
2.10	Seat type	●Premium○Suspension○Suspension+seatbelt logic switch
2.11	Attachments	●No○Built-in sideshifter○External shifter○Adjustable fork
2.13	Traction pin	●Yes
2.14	Electrostatic chain	●Yes
3.5	Front lamp	●LED
3.6	Rear lamp	●No○LED
3.7	Warning lamp	●Yes
3.8	Steering lamp	●Yes
3.9	Blue lamp	●No○2 front○1 rear○2 front + 1 rear
3.10	Area warning lamp	●No○1 left + 1 right (Red)
3.11	Rearview mirror	●1 in the middle○Add 1 rear mirror on both sides
3.12	Buzzer	●Yes
3.17	OPS system	●Yes
3.23	Telematics	●Yes and not customized
4.3	Cabin	●No○Full cabin○Semi-enclosed cabin
4.9	Heater	●No○Yes and not customized

Note: ●Standard ○ Optional - Inconformity

### Fully Closed Cabin (option)



**WAELLER sp. z o.o. sp. k.**

PL 83-034 Trąbki Wielkie, ul. Towarowa 1 • PL 80-457 Gdańsk, ul. Powstańców Wielkopolskich 11

Tel. (+48) 58 683 01 53, 58 691 27 15, 784 046 763, 601 642 339

biuro@ep-eq.pl • www.ep-eq.pl