



EPT20-15EHJ

Semi Electric Truck 1.5t

- Light service weight, large loading capacity, suitable for narrow working space;
- Latest integrative handle design makes reachable control;
- Modularized structure more convenient for troubleshooting and maintenance.

EP EQUIPMENT CO.,LTD
www.ep-eq.eu



▣ FEATURE

■ Light Weight, Great Capacity, Excellent Passingability:

1500KG capacity, light weight and compact size equivalent to hand pallet trucks.

■ External Control System:

The external control system not only protects controller in place but also provides easy access for maintenance.

■ Operation :

Ergonomically-designed tiller head helps increase efficiency;
Internal Charger for Easy Charging.

■ Safety :

Handy Emergency Disconnect Button & Durable Driving Unit ensure safety under any situation.

■ Maintenance :

Modular design of electrical components, Easy for Diagnosis and Replacing.

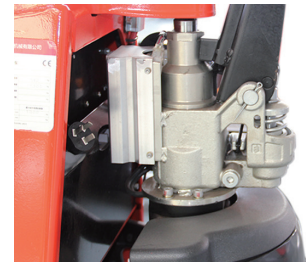
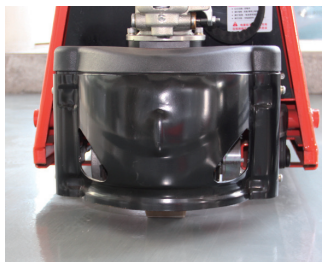
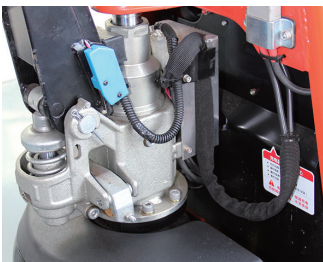

Semi Electric Truck 1.5t

EPT20-15EHJ

Distinguishing mark	1.1	Manufacturer			EP
	1.2	Model designation			EPT20-15EHJ
	1.3	Drive			Electric
	1.4	Operator type			Pedestrian
	1.5	Load capacity	Q	kg	1500
	1.6	Load center distance	c	mm	600
	1.8	Load distance, centre of drive axle to fork	x	mm	882/946
	1.9	Wheelbase	y	mm	1147/1211
	Service weight	2.1	Service weight		kg
2.2		Axle loading, laden front/rear		kg	547/1098
2.3		Axle loading, unladen front/rear		kg	118/27
Tyres/chassis	3.1	Tyre type			Polyurethane
	3.2.1	Tyre size, front		mm	Φ210x70
	3.3.1	Tyre size, rear		mm	2x Φ80x60 (Φ74x88)
	3.4	Additional wheels (castor wheels)		mm	—
	3.5	Wheels, number front/rear (x=drive wheels)		mm	1x /4 (1x /2)
	3.6.1	Tread width, front	b10	mm	—
	3.7.1	Tread width, rear	b11	mm	410 (535)
Dimensions	4.4	Lift height	h3	mm	115
	4.9	Height of tiller handle in drive position min./max.	h14	mm	715/1280
	4.15	Lowered height	h13	mm	85(75)
	4.19	Overall length	l1	mm	1588
	4.20	Length to face of forks	l2	mm	438
	4.21	Overall width	b1/b2	mm	560 (685)
	4.22	Fork dimensions	s/e/l	mm	50/150/1150
	4.25	Distance between fork-arms	b5	mm	560 (685)
	4.32	Ground clearance, center of wheelbase	m2	mm	35(25)
	4.34.1	Aisle width for pallets 1000×1200 crossways	Ast	mm	2136
	4.34.2	Aisle width for pallets 800×1200 crossways	Ast	mm	2193
4.35	Turning radius	Wa	mm	1375	
Performance data	5.1	Travel speed, laden/unladen		km/h	3.5/4
	5.2	Lifting speed, laden/unladen		m/s	10mm/time
	5.3	Lowering speed, laden/unladen		m/s	manual lowering
	5.8	Max. gradeability, laden/unladen		%	5/10
	5.10	Service brake			Electromagnetic
Electric-engine	6.1	Drive motor rating S2 60 min		kW	0.65
	6.2	Lift motor rating at S3 15%		kW	Manual Lifting
	6.4	Battery voltage/nominal capacity		V/Ah	24/30
	6.5	Battery weight		kg	9.5*2
Addition data	8.1	Type of drive control			DC
	10.5	Steering design			Mechanical
	10.7	Sound pressure level at the driver's ear		dB(A)	74

If there are improvements of technical parameters or configurations, no further notice will be given.
The diagram shown may contain non-standard configurations.

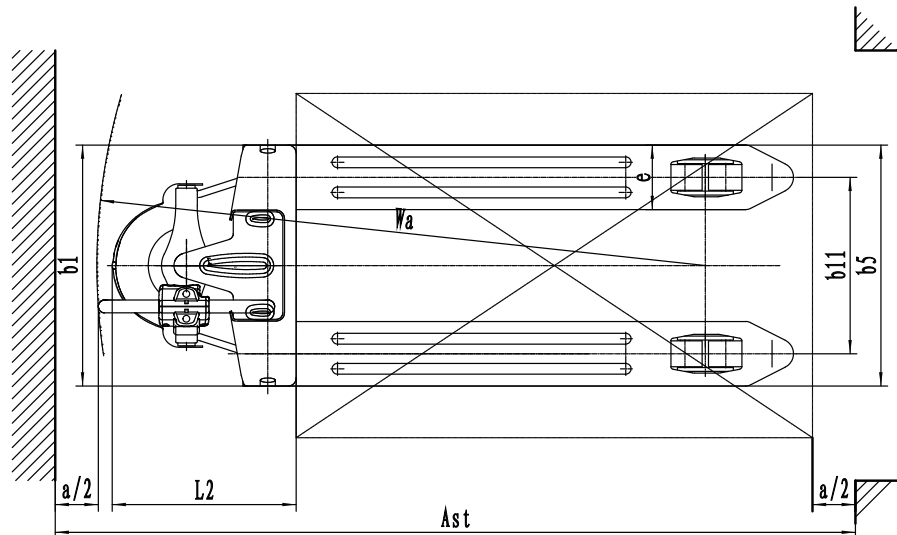
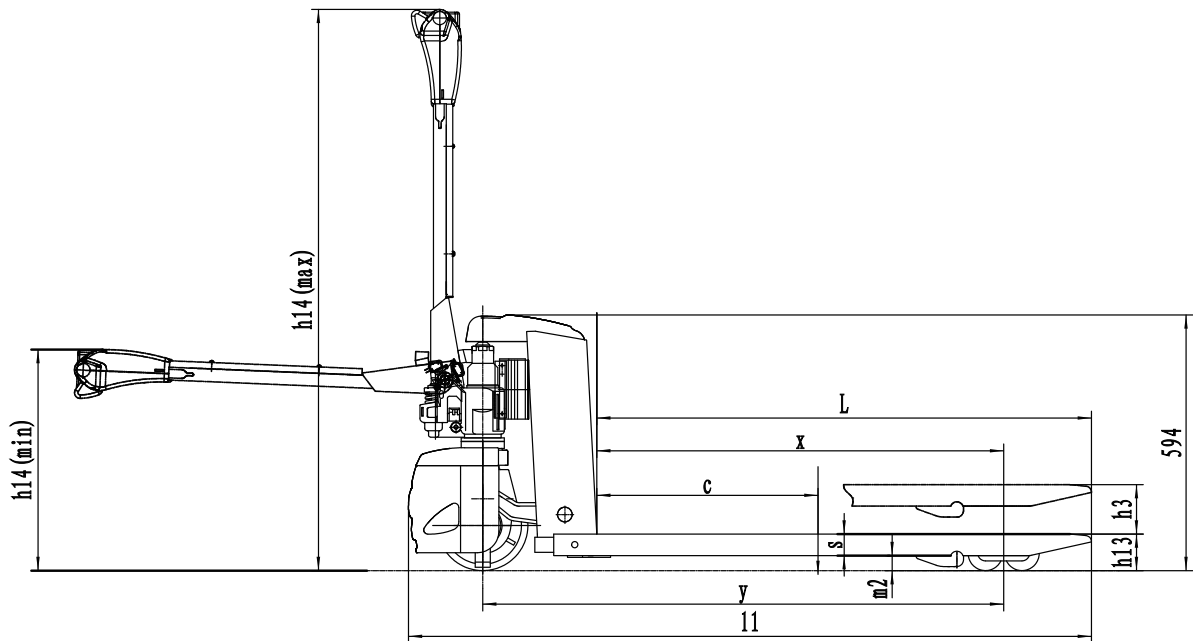

Option

No.	Optional items	EPT20-15EHJ
1.1	Fork dimension	●560*1150、800~1500●685*1150、800~1500 ●520*1150、800~1500●600*1150、800~1500
1.3	Fork lowered height	●85○75
2.1	Load wheel type	●Double○Single
2.2	Load wheel material	●PU
2.3	Drive wheel material	●PU○Trace PU
2.7	Battery capacity	●30Ah
2.8	Charger	●24V-5A Internal
2.9	Battery indicator	●Without time
3.3	Castor wheels	●No○Yes and not customized
3.16	Vertical handler working	●No○One touch start Type handle○With Tortoise speed handle

Note: ●Standard ○Optional - Inconformity

WAELLER sp. z o.o. sp. k.

PL 83-034 Trąbki Wielkie, ul. Towarowa 1 • PL 80-457 Gdańsk, ul. Powstańców Wielkopolskich 11

Tel. (+48) 58 683 01 53, 58 691 27 15, 784 046 763, 601 642 339

biuro@ep-eq.pl • www.ep-eq.pl