



EPT20-15ET2H

Electric Pedestrian Pallet truck 1.5T

- Mature components ensuring reliability
- Waterproof and dust-proof design for rough environments
- Optimized drive wheel to cope with heavy duties and continuous use
- Higher ground clearance available for outdoor usage

EP EQUIPMENT CO.,LTD
www.ep-eq.eu

FEATURE

■ Mature components ensuring reliability

The EPT20-15ET2H inherits the design philosophy of EP's iconic model, EPT20-15ET2, along with market-proven components, AGM battery and standard integrated charger, which convince users of its good quality and reliability.

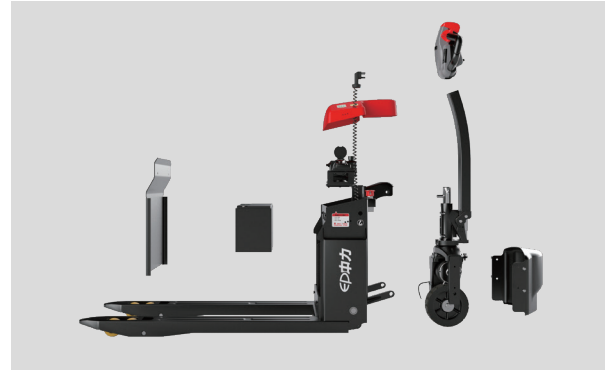

■ Waterproof and dust-proof design for rough environments

The EPT20-15ET2H adopts the fully closed connectors and gearbox, protecting the truck from water or dust ingress. This makes it a workhorse even in muddy and wet scenarios.



■ Optimized drive wheel to cope with heavy duties and continuous use

To cope with heavy duties, EP optimizes the drive wheel and it's easy to swap in case of wear sustained from continuous use. Operators benefit from the truck in terms of durability and easy maintenance.

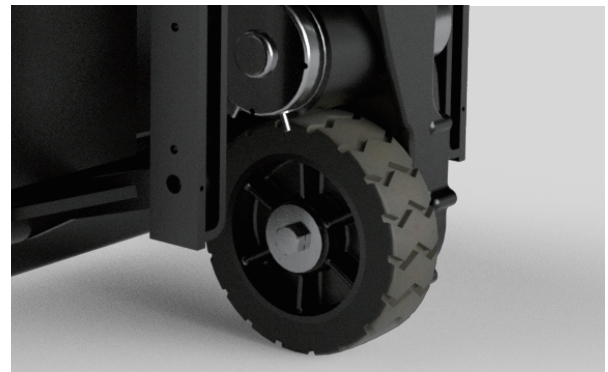

■ Higher ground clearance available for outdoor usage

The EPT20-15ET2H offers 105mm nylon load wheels or 80mm PU load wheels as options and it comes with high ground clearance, to accommodate transportation tasks on construction sites and cold storage.



Electric Pedestrian Pallet truck 1.5T

EPT20-15ET2H

Distinguishing mark	1.1	Manufacturer			EP
	1.2	Model designation			EPT20-15ET2H
	1.3	Drive			Electric
	1.4	Operator type			Standing
	1.5	Load capacity	Q	kg	1500
	1.6	Load center distance	c	mm	600
	1.8	Load distance, centre of drive axle to fork	x	mm	946
	1.9	Wheelbase	y	mm	1301
	Service weight	2.1	Service weight		kg
2.2		Axle loading, laden front/rear		kg	567/1128
2.3		Axle loading, unladen front/rear		kg	155/40
Tyres/chassis	3.1	Tyre type			Polyurethane/Solidrubber
	3.2	Tyre size, front			80*61
	3.3	Tyre size, rear			Φ210x70
	3.4	Additional wheels (castor wheels)		mm	—
	3.5	Wheels, number front/rear (x=drive wheels)		mm	1x, —/4
	3.6.1	Tread width, front	b ₁₀	mm	—
	3.7.1	Tread width, rear	b ₁₁	mm	410 (535)
Dimensions	4.4	Lift height	h ₃	mm	115
	4.9	Height of tiller handle in drive position min./max.	h _{1.4}	mm	790/1250
	4.15	Lowered height	h ₁₃	mm	80
	4.19	Overall length	l ₁	mm	1673
	4.20	Length to face of forks	l ₂	mm	522
	4.21	Overall width	b ₁ /b ₂	mm	560 (685)
	4.22	Fork dimensions	s×e×l	mm	50/150/1150
	4.25	Distance between fork-arms	b ₅	mm	560 (685)
	4.32	Ground clearance, center of wheelbase	m ₂	mm	30
	4.34.1	Aisle width for pallets 1000×1200 crossways	Ast	mm	2307
	4.34.2	Aisle width for pallets 800×1200 lengthways	Ast	mm	2179
4.35	Turning radius	Wa	mm	1505	
Performance data	5.1	Travel speed, laden/unladen		km/h	3.8/4
	5.2	Lifting speed, laden/unladen		m/s	0.027/0.038
	5.3	Lowering speed, laden/unladen		m/s	0.059/0.039
	5.8	Max. gradeability, laden/unladen		%	5/16
	5.10	Service brake			Electromagnetic
Electric-engine	6.1	Drive motor rating S2 60 min		kW	0.75
	6.2	Lift motor rating at S3 15%		kW	0.8
	6.4	Battery voltage/nominal capacity		V/Ah	24/65
	6.5	Battery weight		kg	29
Drive/lift mechanism	8.1	Type of drive control			AC
	10.5	Steering design			Mechanical
	10.7	Sound pressure level at the driver's ear		dB(A)	74

If there are improvements of technical parameters or configurations, no further notice will be given.
The diagram shown may contain non-standard configurations.

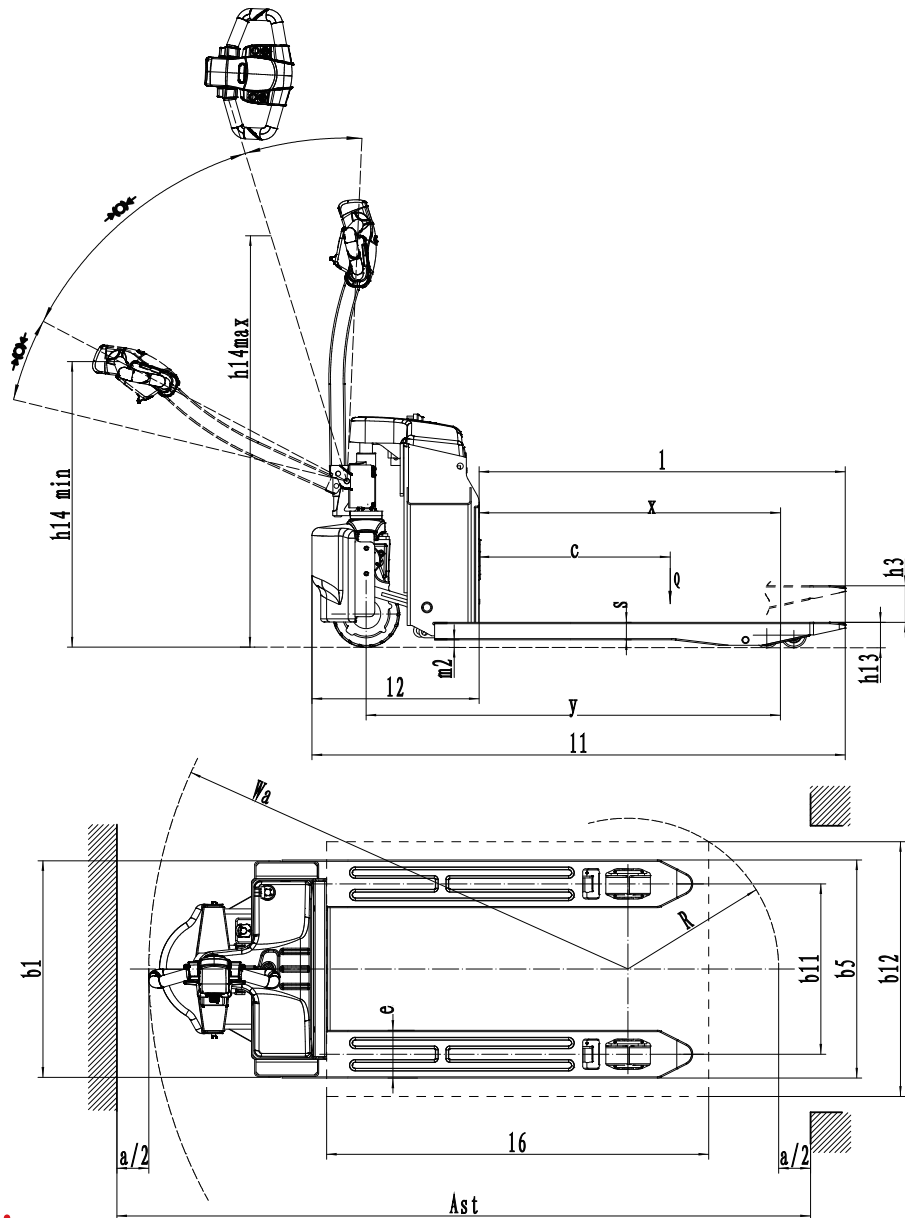

Option:

No.	Optional items	EPT20-15ET2H
1.1	Fork dimension	<ul style="list-style-type: none"> ● 1150*560 ○ 800*560 ○ 900*560 ○ 1000*560 ○ 1220*560 ○ 1300*560 ○ 1400*560 ○ 1500*560 ○ 1600*560 ○ 1800*560 ○ 2000*560 ○ 800*685 ○ 900*685 ○ 1000*685 ○ 1150*685 ○ 1220*685 ○ 1300*685 ○ 1400*685 ○ 1500*685 ○ 1600*685 ○ 1800*685 ○ 2000*685
1.3	Fork lowered height	● 80 ○ 105
1.6	Ground clearance of drive cover	● 50mm ○ 80mm
2.1	Load wheel type	● Double ○ Single
2.2	Load wheel material	● PU(80mm) ○ Nylon(105mm)
2.3	Drive wheel material	● Rubber
2.7	Battery capacity	● 65Ah AGM ○ 85Ah AGM
2.8	Charger	● 24V-10A integrated
2.9	Battery indicator	● With time
2.16	handle head type	● Hands big handle head
3.3	Castor wheels	● No ○ Yes and not customized
3.12	Buzzer	● Yes and not customized
3.16	Turtle speed	● No ○ Yes and not customized

Note: ● Standard ○ Optional - Inconformity

WAELLER sp. z o.o. sp. k.

PL 83-034 Trąbki Wielkie, ul. Towarowa 1 • PL 80-457 Gdańsk, ul. Powstańców Wielkopolskich 11
Tel. (+48) 58 683 01 53, 58 691 27 15, 784 046 763, 601 642 339

biuro@ep-eq.pl • www.ep-eq.pl