



EPT20-18EA

Electric Pallet Truck 1.8t

- **Delivery Truck:** The Last Mile Solution Truck
Customised for Half Pallet Handling, Dock Tail Trailer
- **Applicable Industry:** Mailing, Beverage, Food, Retail, Convenient Stores, etc.

EP EQUIPMENT CO.,LTD
www.ep-eq.eu



Electric Pallet Truck 1.8t EPT20-18EA

Distinguishing mark	1.1	Manufacturer			EP
	1.2	Model designation			EPT20-18EA
	1.3	Drive			Electric
	1.4	Operator type			Pedestrian
	1.5	Load capacity	Q	kg	1800
	1.6	Load center distance	c	mm	600
	1.8	Load distance, centre of drive axle to fork	x	mm	945
	1.9	Wheelbase	y	mm	1270
	Service weight	2.1	Service weight		kg
2.2		Axle loading, laden front/rear		kg	770/1315
2.3		Axle loading, unladen front/rear		kg	230/55
Tyres/chassis	3.1	Tyre type			Polyurethane
	3.2.1	Tyre size, front		mm	Φ80x60
	3.3.1	Tyre size, rear		mm	Φ230x75
	3.4	Additional wheels (castor wheels)		mm	Φ85x48
	3.5	Wheels, number front/rear (x=drive wheels)		mm	1x+2/4
	3.6.1	Tread width, front	b10	mm	435
	3.7.1	Tread width, rear	b11	mm	390/495/535
Dimensions	4.4	Lift height	h3	mm	105
	4.9	Height of tiller handle in drive position min./max.	h14	mm	715/1200
	4.15	Lowered height	h13	mm	85
	4.19	Overall length	l1	mm	1625
	4.20	Length to face of forks	l2	mm	491
	4.21	Overall width	b1/b2	mm	645
	4.22	Fork dimensions	s/e/l	mm	50x150x1150
	4.25	Distance between fork-arms	b5	mm	540/685
	4.32	Ground clearance, center of wheelbase	m2	mm	35
	4.34.1	Aisle width for pallets 1000×1200 crossways	Ast	mm	2258
	4.34.2	Aisle width for pallets 800×1200 crossways	Ast	mm	2120
4.35	Turning radius	Wa	mm	1457	
Performance data	5.1	Travel speed, laden/unladen		km/h	4.5/5
	5.2	Lifting speed, laden/unladen		m/s	0.051/0.060
	5.3	Lowering speed, laden/unladen		m/s	0.032/0.039
	5.8	Max. gradeability, laden/unladen		%	6/16
	5.10	Service brake			Electromagnetic
Electric-engine	6.1	Drive motor rating S2 60 min		kW	1.1
	6.2	Lift motor rating at S3 15%		kW	0.84
	6.4	Battery voltage/nominal capacity		V/Ah	2x12/85
	6.5	Battery weight		kg	25x2
Addition data	8.1	Type of drive control			AC
	10.5	Steering design			Mechanical
	10.7	Sound pressure level at the driver's ear		dB(A)	74

If there are improvements of technical parameters or configurations, no further notice will be given.
The diagram shown may contain non-standard configurations.



- World' s 1st Half Pallet Truck
- High Traction, Indoor and Outdoor Perfect Handling
- Long Battery Running Time, Larger Battery Installment Option, Full day Job Handling
- Small Turning Radius, Excellent Maneuverability Inside Trailer
- On-board Charger, Easy to Charge
- Customized Solution Available

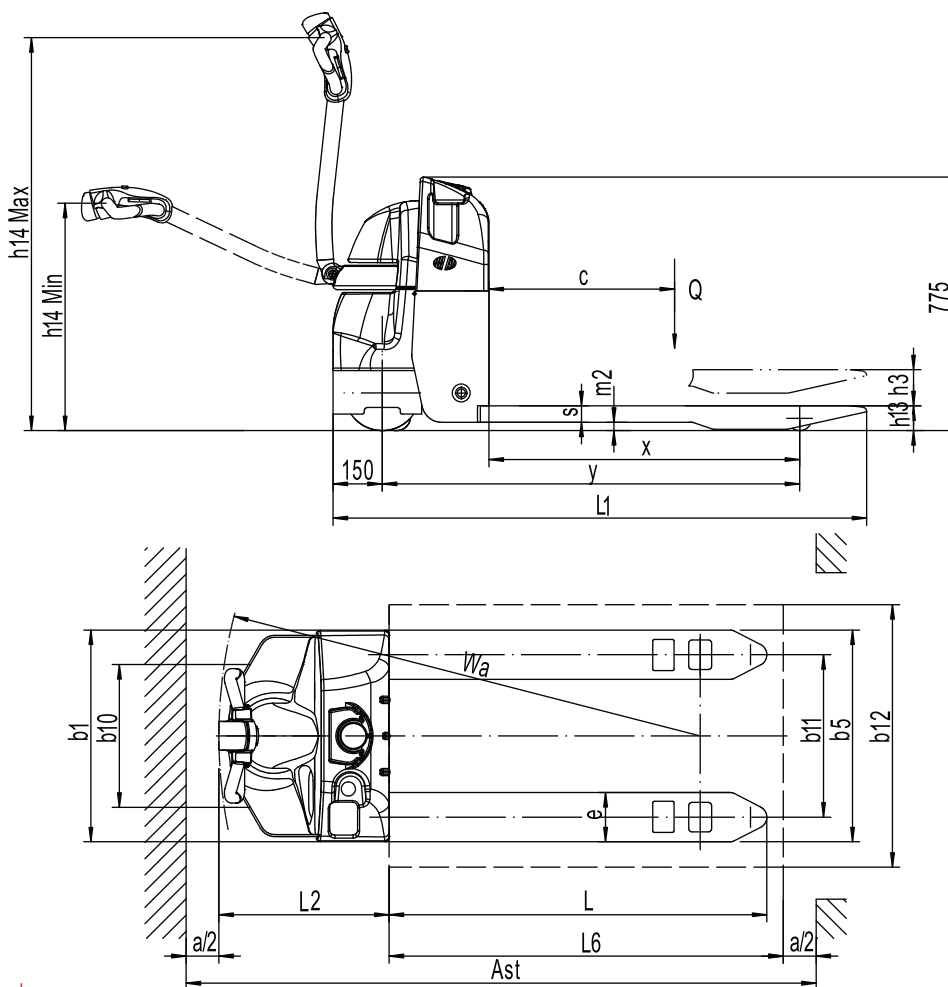

Solution Packages:

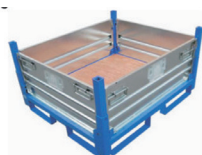

Options

No.	Optional items	EPT20-18EA
1.1	Fork dimension	●685*1150○685* (850, 915, 1000, 1220, 1300, 1450) ○540* (850, 915, 1000, 1150, 1220, 1300, 1450)
1.3	Fork lowered height	●85
1.4	Fork carriage width	661
1.5	backrest height	○1220mm (48in) ○1520mm (60in)
2.1	Load wheel type	●Double
2.2	Load wheel material	●PU
2.3	Drive wheel material	●PU○Patterned PU○Rubber
2.7	Battery capacity	●85Ah
2.8	Charger	●24V-15A Internal
2.9	Battery indicator	●With time
3.3	Castor wheels	●Yes and not customized○No
3.16	Vertical handler working	●Yes and not customized
4.2	Cold storage	●No○Yes and not customized
5.8	Brake release button	●Yes and not customized

Note: ●Standard ○ Optional - Inconformity

WAELLER sp. z o.o. sp. k.

PL 83-034 Trąbki Wielkie, ul. Towarowa 1 • PL 80-457 Gdańsk, ul. Powstańców Wielkopolskich 11
Tel. (+48) 58 683 01 53, 58 691 27 15, 784 046 763, 601 642 339

biuro@ep-eq.pl • www.ep-eq.pl