



EPT20-RAP

Low Order Picker 2.0t

Electronic Power Steering Makes Operation Easy & Fast;
AC Driving Motor Offers Stronger Power to Obtain Top Speed of 12KM/H;
Slowing-down in Curved Aisle Ensures the Smoothness and Stability.

EP EQUIPMENT CO.,LTD
www.ep-eq.eu



FEATURE



Performance

- The innovative AC system offers strong power, accurate control, excellent performance.
- High strength vertical gearbox, longer working life.
- Low-noise but durable hydraulic unit, good quality cylinder as well as hose ensure the high reliability of hydraulic system.
- AMP connector and durable electric wires greatly reduce malfunctions of components.
- High speed(Up to 12km/h unladen), High Efficiency of Material Handling Operations.

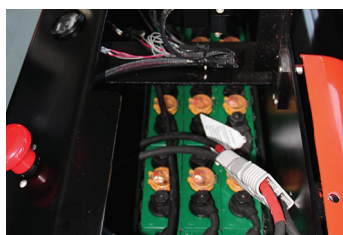

Safety

- Safety foot switch avoids operators from misoperation.
- Automatic braking and reverse current braking when foot switch is off or travel switch is neutral.
- Emergency disconnect will cut off power source to avoid accident when truck goes out of control.
- The function of skidproof brake avoid the truck skidding down when truck goes out of control or travelling on grade.
- Dual-monitoring power steering.

Operation

- With the new design of ergonomical tiller head, all buttons can be reached conveniently & comfortably.
- With backrest cushion, spacious operation room and vibration absorber pedal, the operator feels more comfortable.
- Side-open battery compartment design for easy replacement and maintenance.
- Coast control function, convenient for order picking.
- Electric power steering, smooth & comfortable (EPS).

Maintenance

- AC traction motor, maintenance free.
- Hour meter and battery indicator remind the operator of battery charging.
- Easily remove the back cover by only losing two bolts; Access to all key components for inspection, maintenance and replacement.
- Vertical motor makes the inspection & service much more convenient.
- Control system allows easy trouble-shooting.
- Low voltage lift cut off design protects the battery.

Low order picker 2.0t EPT20-RAP

Distinguishing mark	1.1	Manufacturer			EP
	1.2	Model designation			EPT20-RAP
	1.3	Drive			Electric
	1.4	Operator type			Standing
	1.5	Load capacity	Q	kg	2000
	1.6	Load center distance	c	mm	600
	1.8	Load distance, centre of drive axle to fork	x	mm	980
	1.9	Wheelbase	y	mm	2161
	Service weight	2.1	Service weight		kg
2.2		Axle loading, laden front/rear		kg	1200/1740
2.3		Axle loading, unladen front/rear		kg	780/160
Tyres/chassis	3.1	Tyre type			Polyurethane
	3.2	Tyre size, front		mm	Φ85x70/Φ83x115
	3.3	Tyre size, rear		mm	Φ230x90
	3.4	Additional wheels (castor wheels)		mm	Φ180x65
	3.5	Wheels, number front/rear (x=drive wheels)		mm	1x +1/4/1x +1/2
	3.6	Tread width, front	b10	mm	468
	3.7	Tread width, rear	b11	mm	370/515
Dimensions	4.4	Lift height	h3	mm	120
	4.9	Height of tiller handle in drive position min./max.	h14	mm	1220
	4.15	Lowered height	h13	mm	85
	4.19	Overall length	l1	mm	2516
	4.20	Length to face of forks	l2	mm	1366
	4.21	Overall width	b1/b2	mm	800
	4.22	Fork dimensions	s/e/l	mm	55/170/1150
	4.25	Distance between fork-arms	b5	mm	540/685
	4.32	Ground clearance, center of wheelbase	m2	mm	30
	4.34.1	Aisle width for pallets 1000×1200 crossways	Ast	mm	3190
4.34.2	Aisle width for pallets 800×1200 crossways	Ast	mm	3025	
4.35	Turning radius	Wa	mm	2390	
Performance data	5.1	Travel speed, laden/unladen		km/ h	9/12
	5.2	Lifting speed, laden/unladen		m/s	0.026/0.034
	5.3	Lowering speed, laden/unladen		m/s	0.025/0.021
	5.8	Max. gradeability, laden/unladen		%	8/13
	5.10	Service brake			Electromagnetic
Electric-engine	6.1	Drive motor rating S2 60 min		kW	2.5
	6.2	Lift motor rating at S3 15%		kW	2.2
	6.4	Battery voltage/nominal capacity		V/Ah	24/360
	6.5	Battery weight		kg	330
	Addition data	8.1	Type of drive control		
10.5		Steering design			Electronic
10.7		Sound pressure level at the driver's ear		dB(A)	74

If there are improvements of technical parameters or configurations, no further notice will be given.
The diagram shown may contain non-standard configurations.

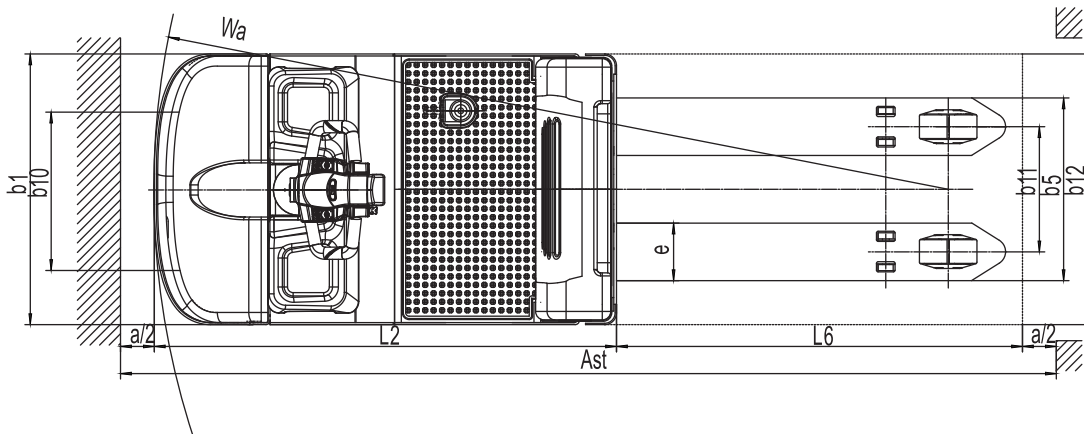
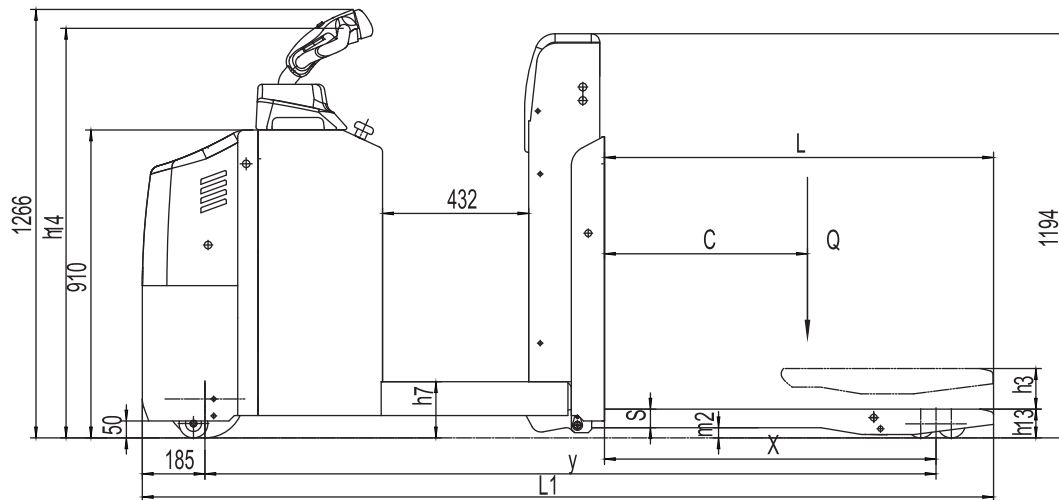

Option

No.	Optional items	EPT20-RAP
1.1	Fork dimension	<ul style="list-style-type: none"> ●685*1150○685* (850、1000、1220、1300、1450、1600、1800、2000、2200、2400) ○540* (850、1000、1150、1220、1300、1450、1600、1800、2000、2200、2400)
1.3	Fork lowered height	●85
2.1	Load wheel type	●Double○Single
2.2	Load wheel material	●PU
2.3	Drive wheel material	●PU○Patterned PU○Rubber
2.7	Battery capacity	●360Ah (Lead-acid) ○280Ah (Lead-acid) ○210Ah (Lead-acid)
2.8	Charger	●24V-50A External (Lead-acid) ○24V-30A External (Lead-acid)
2.9	Battery indicator	●With time
3.3	Castor wheels	●Yes and not customized
3.4	Water auto-filling system	●No○Yes and not customized
4.1	Battery side pull function	●Yes and not customized
5.1	Battery side pull attachment	●No○Yes and not customized
5.6	Side pull trolley	●No○Yes and not customized

Note: ●Standard ○Optional - Inconformity

WAELLER sp. z o.o. sp. k.

PL 83-034 Trąbki Wielkie, ul. Towarowa 1 • PL 80-457 Gdańsk, ul. Powstańców Wielkopolskich 11

Tel. (+48) 58 683 01 53, 58 691 27 15, 784 046 763, 601 642 339

biuro@ep-eq.pl • www.ep-eq.pl