



ES06-CA

Electric Stacker 0.6 t

- Compact design with small turning radius requirements;
- Flexible for various non-standard pallet.

EP EQUIPMENT CO.,LTD
www.ep-eq.eu



FEATURE

Performance

- The innovative AC system offers strong power, accurate control, excellent performance.
- High strength vertical gearbox, longer working life.
- Low-noise but durable hydraulic unit, good quality cylinder as well as hose ensure the high reliability of hydraulic system.
- AMP connector electric wires and cables, greatly reducing electric parts failure rate.
- High strength chassis enhances the reliability and durability of the truck.
- Heavy duty load wheel ensures stability.
- Compact design with small turning radius requirements.



Safety

- Emergency reverse belly button protects the operator from getting hurt.
- Emergency disconnecter will cut off power source to avoid accident when truck goes out of control.
- Multiple lifting limit protection ensures safety.
- Automatic switch to lower speed when the fork reaches its setting height.
- Anti-rolling back brake keeps the truck from skidding down when truck is out of control or travelling on ramp.

Operation

- With the new design of ergonomical tiller head, all buttons can be reached conveniently & comfortably.
- Compact chassis design increases visibility.
- Adjustable forks, suitable for complicated pallets or cargos.
- Side-open battery design for easy battery replacement and various applications.

Maintenance

- AC traction motor, maintenance free.
- Hour meter and battery indicator will remind the operator to recharge the battery.
- Easily remove the back cover by only losing four bolts; Access to all key components for inspection, maintenance and replacement.
- Vertical motor makes the inspection & service much more convenient.
- Control system allows easy trouble-shooting.
- Mast and chassis are assembled together, easy for maintenance.
- Low voltage cut off setting protects batteries.

Electric Stacker 0.6t

ES06-CA

Distinguishing mark				
1.1	Manufacturer			EP
1.2	Model designation			ES06-CA
1.3	Drive unit			Electrical
1.4	Operator type			pedestrian
1.5	rated capacity	Q	kg	600
1.6	Load center distance	c	mm	500
1.8	Load distance, centre of drive axle to fork	x	mm	109
1.9	Wheelbase	y	mm	700
Weight				
2.1	Service weight (include battery)		kg	1300
2.2	Axle loading, laden driving side/loading side		kg	300/1900
2.3	Axle loading, unladen driving side/loading side		kg	860/440
Types,Chassis				
3.1	Tyre type Driving wheels/Loading wheels			PU/PU
3.2	Tyre size, driving wheels (diameter×width)		mm	Φ230× 75
3.3	Tyre size, loading wheels (diameter×width)		mm	Φ204×76
3.4	Tyre size, caster wheels (diameter×width)		mm	/
3.5	Wheels, number driving, caster/loading (x=drive wheels)		mm	1x, 0/2
3.6	Track width, front,driving side	b ₁₀	mm	722
3.7	Track width,rear,loading side	b ₁₁	mm	/
Dimensions				
4.1	Tilt of mast/fork carriage forward/backward	α/β	°	/
4.2	Height, mast lowered	h ₁	mm	2035
4.3	Free lift	h ₂	mm	/
4.4	Lift height	h ₃	mm	3020
4.5	Height, mast extended	h ₄	mm	3896
4.9	Height drawbar in driving position min./max.	h ₁₄	mm	990/1500
4.10	Height of wheel arms	h ₈	mm	230
4.19	Overall length	l ₁	mm	1920
4.20	Length to face of forks	l ₂	mm	1000
4.21	Overall width	b ₁ / b ₂	mm	850/798
4.22	Fork dimensions	s/ e/ l	mm	35/100/920
4.24	Fork carriage width	b ₃	mm	820
4.25	Outside width of the forks	b ₅	mm	200-560
4.31	Ground clearance, laden, below mast	m ₁	mm	50
4.32	Ground clearance, center of wheelbase	m ₂	mm	50
4.34.1	Aisle width for pallets 1000 × 1200 crossways	A _{st}	mm	2380
4.34.2	Aisle width for pallets 800 × 1200 lengthways	A _{st}	mm	2490
4.35	Turning radius	W _a	mm	920
Performance data				
5.1	Travel speed, laden/ unladen		km/ h	4.5
5.2	Lifting speed, laden/ unladen		m/ s	0.127/0.23
5.3	Lowering speed, laden/ unladen		m/ s	0.26/0.2
5.8	Max. gradeability, laden/unladen		%	5.0/8.0
5.10	Service brake type			Electromagnetic
Electric engine				
6.1	Drive motor rating S2 60 min		kW	1.5
6.2	Lift motor rating at S3 15%		kW	2.2
6.3	The maximum allowed size battery		mm	660/230/open
6.4	Battery voltage/nominal capacity K5		V/ Ah	24/165
6.5	Battery weight		kg	160
Addition data				
8.1	Type of drive unit			AC
10.5	Steering type			Mechanical
10.7	Sound pressure level at the driver's ear		dB(A)	74

If there are improvements of technical parameters or configurations, no further notice will be given.
The diagram shown may contain non-standard configurations.

RATED CAPACITIES GRAPH

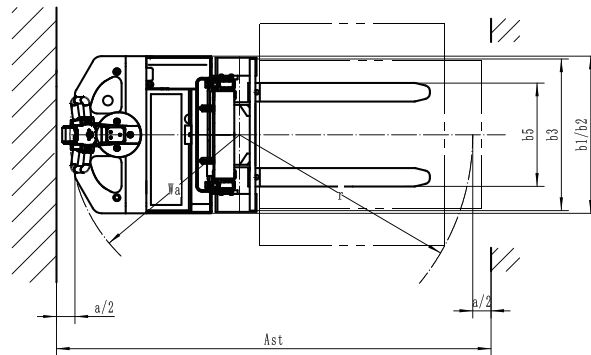
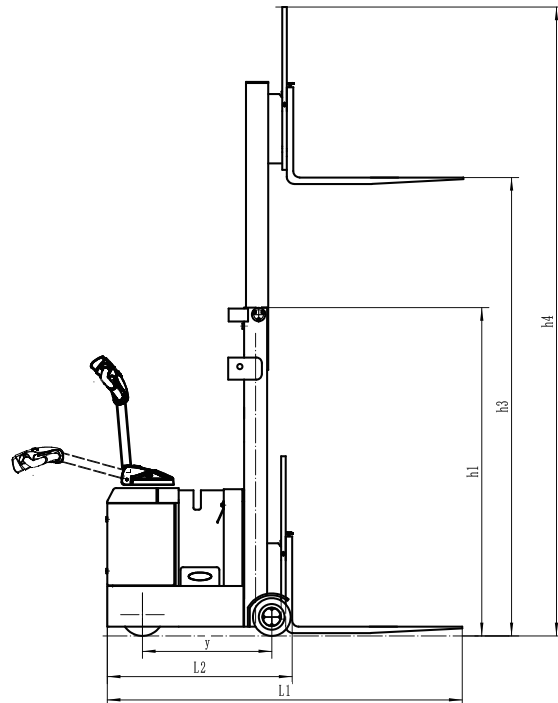
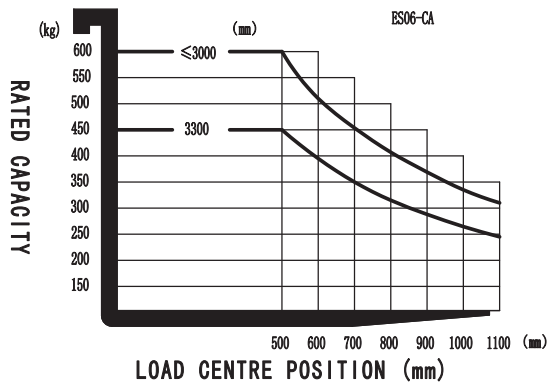

Mast Option

Mast types	Lift height (h3)	Height, Mast			Height, Free lift(h2)	
		Height, mast lowered(h1)	Height, mast extended(h4)		No shelving	With shelving
			No shelving	With shelving		
	mm	mm	mm	mm	mm	mm
2-Standard Mast	2500	1785	-	3396	-	-
2-Standard Mast	2700	1885	-	3596	-	-
2-Standard Mast	3000	2035	-	3896	-	-
2-Standard Mast	3300	2185	-	4196	-	-
2-Standard Mast	3600	2335	-	4496	-	-

Option

No.	Optional items	ES06-CA
1.1	Fork dimension	●600*600, 2A、100*35*920○600*600, 2A、100*35*1070 ○900*600, 2A、100*40*1150○900*600, 2A、100*40*1220 ○900*600, 2A、100*40*1370
1.3	Fork lowered height	●60
1.4	Fork carriage width	●820
1.5	backrest height	●917mm
2.2	Load wheel material	●PU
2.3	Drive wheel material	●PU
2.7	Battery capacity	●165Ah○210Ah
2.8	Charger	●24V-20A External○24V-30A External
2.9	Battery indicator	●With time
3.4	Water auto-filling system	●No○Yes and not customized
3.21	Fodable pedal	●No○Yes and not customized

Note: ●Standard ○Optional - Inconformity

WAELLER sp. z o.o. sp. k.

PL 83-034 Trąbki Wielkie, ul. Towarowa 1 • PL 80-457 Gdańsk, ul. Powstańców Wielkopolskich 11
Tel. (+48) 58 683 01 53, 58 691 27 15, 784 046 763, 601 642 339

biuro@ep-eq.pl • www.ep-eq.pl