



ES08-WAi Mono Mast

Electric Stacker With Initial Lift 0.8t

Carrying Two Pallets at A Time Doubles Working Efficiency;
Extraordinary Traction in Crossing Door and Dock;
Long-tiller Design Makes Operations Easy and Convenient.

EP EQUIPMENT CO.,LTD
www.ep-eq.eu



FEATURE

Performance

- The innovative AC system offers strong power, accurate control, excellent performance.
- High strength vertical gearbox, longer working life.
- Low-noise but durable hydraulic unit, good quality cylinder as well as hose ensure the high reliability of hydraulic system.
- AMP connector and durable electric wires greatly reduce malfunctions of components.
- H shape channel mast improves the strength of the whole truck.

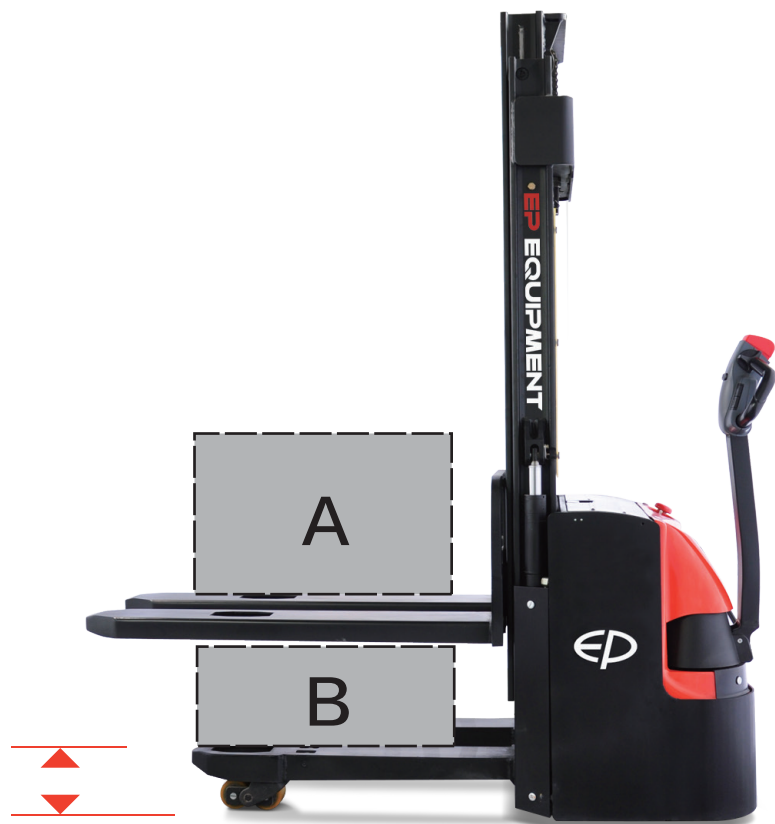

Safety

- Safe hydraulic system design prevents mast from falling down abruptly when hydraulic pipeline cuts off.
- Emergency reverse belly button protects the operator from getting hurt.
- Emergency disconnecter will cut off power source to avoid accident when truck goes out of control.
- Multiple lifting limit protection ensures safety.
- Automatic switch to lower speed when the fork reaches its setting height.
- Anti-rolling back brake keeps the truck from skidding down when truck is out of control or travelling on ramp.

Operation

- With the new design of ergonomical tiller head, all buttons can be reached conveniently & comfortably.
- Dual pallets lifting doubles working efficiency.
- Creep speed function: when handle in near vertical position, the driving speed will decrease automatically, allowing delicate operation in confined space.
- Long tiller decreases the operation force greatly and makes operations much easier.
- Bias Operation, Greater View.

Maintenance

- AC traction motor, maintenance free.
- Hour meter and battery indicator remind the operator of battery charging.
- Easily remove the back cover by only loosening two bolts; Access to all key components for inspection, maintenance and replacement.
- Easy access for battery maintenance.
- Vertical motor makes the inspection & service much more convenient.
- Mast and chassis are assembled together, easy for maintenance.
- Low voltage cut off setting protects batteries.

Electric Stacker 0.8t

ES08-WAi Mono Mast

Distinguishing mark				
1.1	Manufacturer			EP
1.2	Model designation			ES08-WAi
1.3	Drive unit			Electrics
1.4	Operator type			pedestrian
1.5	rated capacity	Q	kg	800
	Support arm capacity/fork and support arm capacity	Q	kg	2000
1.6	Load center distance	c	mm	600
1.8	Load distance, centre of drive axle to fork	x	mm	813
1.9	Wheelbase	y	mm	1275
Weight				
2.1	Service weight (include battery)		kg	660
2.2	Axle loading, laden driving side/loading side		kg	750/1910
2.3	Axle loading, unladen driving side/loading side		kg	450/210
Types,Chassis				
3.1	Tyre type Driving wheels/Loading wheels			pu/pu
3.2	Tyre size, driving wheels (diameter×width)		mm	Φ230x75
3.3	Tyre size, loading wheels (diameter×width)		mm	Φ85x70
3.4	Tyre size, caster wheels (diameter×width)		mm	Φ85x48
3.5	Wheels, number driving, caster/loading (x=drive wheels)		mm	1 x +2 / 4
3.6	Track width, front,driving side	b ₁₀	mm	505
3.7	Track width,rear,loading side	b ₁₁	mm	366
Dimensions				
4.2	Height, mast lowered	h ₁	mm	1860
4.3	Free lift	h ₂	mm	1410
4.4	Lift	h ₃	mm	1480
	Lift height	h ₂₃	mm	1685
4.5	Height, mast extended	h ₄	mm	1895
4.6	Initial lift	h ₅	mm	120
4.9	Height drawbar in driving position min./max.	h ₁₄	mm	715 / 1200
4.15	Lowered height	h ₁₃	mm	95
4.19	Overall length	l ₁	mm	1776
4.20	Length to face of forks	l ₂	mm	666
4.21	Overall width	b ₁ / b ₂	mm	738/710
4.22	Fork dimensions	s/ e/ l	mm	60/190/1150
4.24	Fork carriage width	b ₃	mm	680
4.25	Outside width of the forks	b ₅	mm	560
4.31	Ground clearance, laden, below mast	m ₁	mm	30
4.32	Ground clearance, center of wheelbase	m ₂	mm	30
4.34.1	Aisle width for pallets 1000 × 1200 crossways	Ast	mm	2274
4.34.2	Aisle width for pallets 800 × 1200 lengthways	Ast	mm	2198
4.35	Turning radius	Wa	mm	1442
Performance data				
5.1	Travel speed, laden/ unladen		km/ h	5/5.5
5.2	Lifting speed, laden/ unladen		m/ s	0.14/0.2
5.3	Lowering speed, laden/ unladen		m/ s	0.2/0.13
5.8	Max. gradeability, laden/unladen		%	8/16
5.10	Service brake type			Electromagnetic
Electric-engine				
6.1	Drive motor rating S2 60 min		kW	1.27
6.2	Lift motor rating at S3 15%		kW	2.2
6.3	The maximum allowed size battery		mm	260x260x180
6.4	Battery voltage/nominal capacity K20		V/ Ah	4x6V/224
6.5	Battery weight		kg	4x30
Addition data				
8.1	Type of drive unit			AC
10.5	Steering type			Mechanical
10.7	Sound pressure level at the driver's ear		dB(A)	74

If there are improvements of technical parameters or configurations, no further notice will be given.
The diagram shown may contain non-standard configurations.

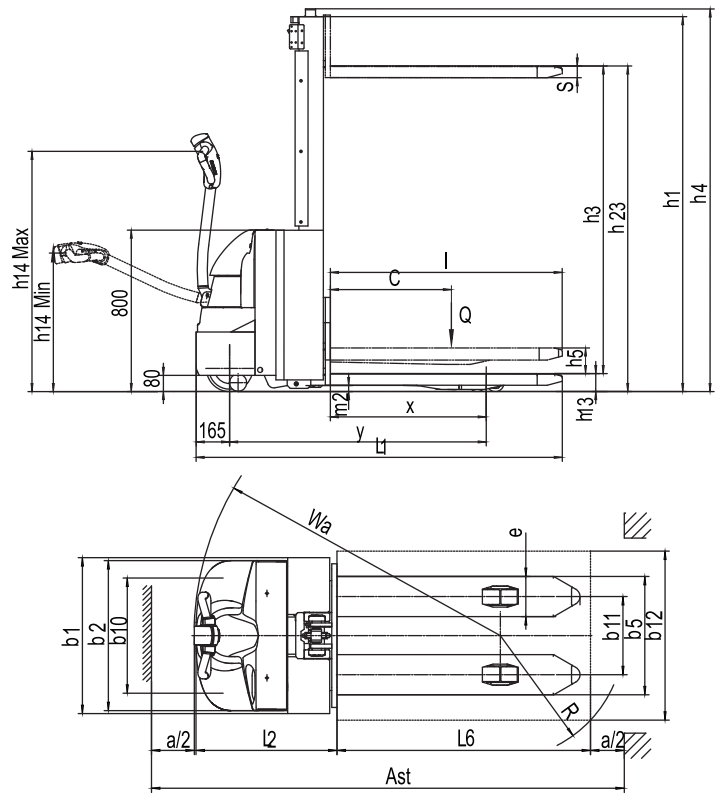

RATED CAPACITIES GRAPH

		lift Height (mm)	Capacity (kg)
	Mast Fork A	1600	800
	Support Arm B	210	A+B≤2000

Option

Options	ES08-WAi
Driving wheel	<ul style="list-style-type: none"> ● PU ○ Rubber wheel/PU wheel with Pattern
Balance wheel	●
Battery capacity	○ 224Ah
Battery indicator with hour meter	●
Battery indicator without hour meter	○
Proportional lifting	○
Height limitation	○
Vertical handler working	○
Water auto-filling system	○

Note: ● standard ○ option — NA

WAELLER sp. z o.o. sp. k.

PL 83-034 Trąbki Wielkie, ul. Towarowa 1 • PL 80-457 Gdańsk, ul. Powstańców Wielkopolskich 11
 Tel. (+48) 58 683 01 53, 58 691 27 15, 784 046 763, 601 642 339
 biuro@ep-eq.pl • www.ep-eq.pl