



▲ CE version



RSB141

Electric Stacker 1.4T

- Strong drive power
- Operation safety assurance
- Easy steering

EP EQUIPMENT CO.,LTD
www.ep-eq.eu

FEATURE

■ Strong drive power

RSB141 adopts EP' s second generation BLDC motor drive technology to offer strong drive power and save the maintenance trouble of replacing carbon brushes.

■ Easy steering

The truck is equipped with electronic steering as standard to reduce steering strains and to offer better maneuverability in operation.

■ Operation safety assurance

RSB141 is proven safety by passing the industrial rollover test. Intelligence auto-break making it a safe helper when working on the slope. The low ground clearance also lowers the risk of foot injuries significantly.

■ Better stability of stacking

RSB141 comes with a tiller which provides two-speed lowering function. Operators can take advantage of different speed modes to enable more precise fork control and achieve better stability of goods stacking.



Electric Stacker 1.4T

RSB141

Distinguishing mark	1.1	Manufacturer			EP
	1.2	Model designation			RSB141
	1.3	Drive			Electric
	1.4	Operator type			Standing
	1.5	Load capacity	Q	kg	1400
	1.6	Load center distance	c	mm	600
	1.8	Load distance, centre of drive axle to fork	x	mm	690
	1.9	Wheelbase	y	mm	1145
	Service weight	2.1	Service weight		kg
2.2		Axle loading, laden front/rear		kg	620/1550
2.3		Axle loading, unladen front/rear		kg	530/240
Tyres/chassis	3.1	Tyre type			Polyurethane
	3.2	Tyre size, front		mm	Φ230×75
	3.3	Tyre size, rear		mm	Φ85×95
	3.4	Additional wheels (castor wheels)		mm	Φ130×55
	3.5	Wheels, number front/rear (x=drive wheels)		mm	1x +1/2
	3.6	Tread width, front	b10	mm	539
	3.7	Tread width, rear	b11	mm	406
Dimensions	4.0	Max. Lift Height	H	mm	3000
	4.2	Retracted mast height	h1	mm	1970
	4.3	Free lift	h2	mm	—
	4.4	Lift height	h3	mm	2915
	4.5	Height, mast extended	h4	mm	3425
	4.6	Initial lift	h5	mm	—
	4.9	Height of tiller handle in drive position min./max.	h14	mm	1150/1480
	4.10	Height of wheel arms	h8	mm	—
	4.15	Lowered height	h13	mm	85
	4.19	Overall length	l1	mm	1754
	4.20	Length to face of forks	l2	mm	604
	4.21	Overall width	b1/b2	mm	800
	4.22	Fork dimensions	s/e/l	mm	60×170×1150
	4.24	Fork carriage width	b3	mm	750
	4.25	Distance between fork-arms	b5	mm	570
	4.26	Distance between wheel arms/loading surfaces	b4	mm	—
	Performance data	4.31	Ground clearance, laden, below mast	m1	mm
4.32		Ground clearance, center of wheelbase	m2	mm	25
4.34.1		Aisle width for pallets 1000×1200 crossways	Ast	mm	2330
4.34.2		Aisle width for pallets 800×1200 crossways	Ast	mm	2300
4.35		Turning radius	Wa	mm	1455
5.1		Travel speed, laden/unladen		km/h	5/5.5
5.2		Lifting speed, laden/unladen		m/s	0.10/0.18
5.3		Lowering speed, laden/unladen		m/s	0.29/0.19
5.8		Max. gradeability, laden/unladen		%	3/10
5.10		Service brake			Electromagnetic
Electric-engine	6.1	Drive motor rating S2 60 min		kW	0.9
	6.2	Lift motor rating at S3 15%		kW	2.2
	6.4	Battery voltage/nominal capacity		V/Ah	48/85(AGM)
	6.5	Battery weight		kg	15×4
Addition data	8.1	Type of drive control			DC
	10.5	Steering design			Electronic
	10.7	Sound pressure level at the driver's ear		dB(A)	74

If there are improvements of technical parameters or configurations, no further notice will be given.
The diagram shown may contain non-standard configurations.

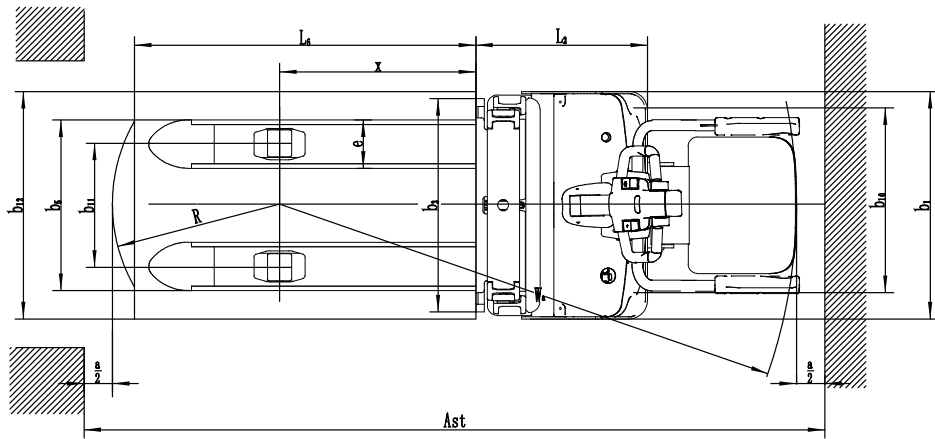
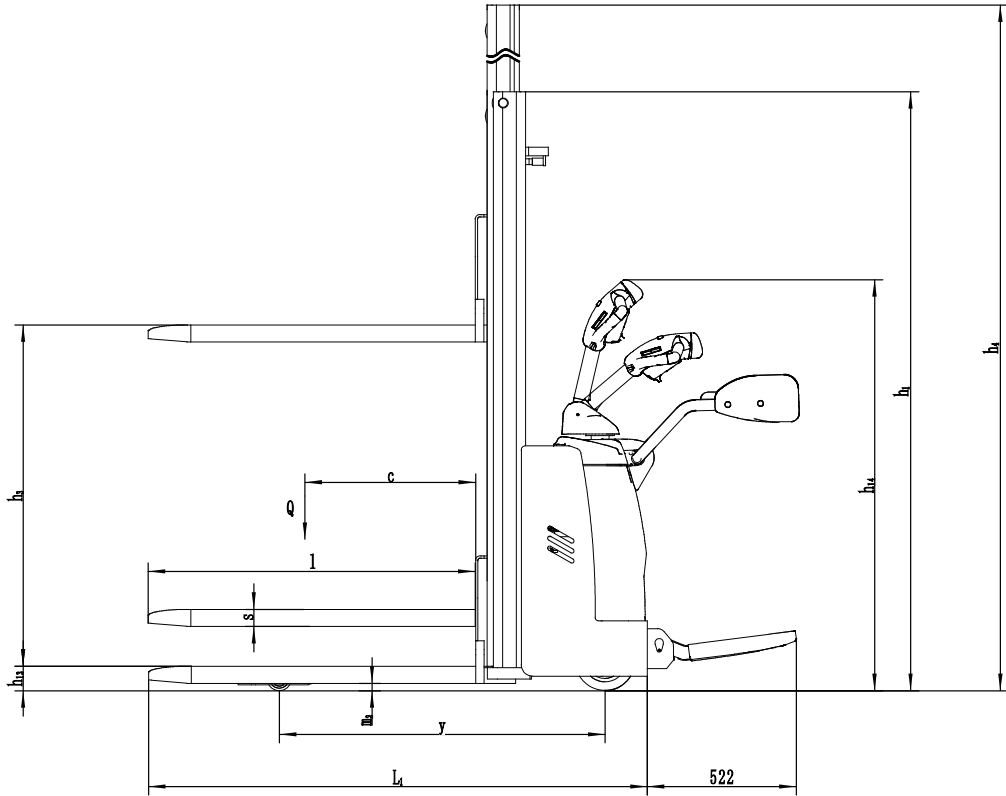

RATED CAPACITIES GRAPH



Mast Option

Mast types	Lift height h3+h13 (mm)	Height, mast lowered h1 (mm)	Free lift h2 (mm)	Height, mast extended h4 (mm)
2-Standard Mast	2515	1710	—	2925
	2715	1810	—	3125
	3015	1960	—	3425
	3315	2110	—	3725
	3615	2260	—	4025
	3915	2410	—	4325

Option

No.	Optional items	RSB141
1.1	Fork length	●1150○1220
1.2	Fork width	●570○685
1.3	Fork lowered height	●85
2.1	Load wheel type	●Single
2.2	Load wheel material	●PU
2.3	Drive wheel material	●PU
2.7	Battery capacity	●85Ah
2.8	Charger	●48V-10A Internal
2.9	Battery indicator	●With time
3.2	Fork carriage	●
3.3	Castor wheels	●

Note: ●Standard ○ Optional - Inconformity

WAELLER sp. z o.o. sp. k.

PL 83-034 Trąbki Wielkie, ul. Towarowa 1 • PL 80-457 Gdańsk, ul. Powstańców Wielkopolskich 11

Tel. (+48) 58 683 01 53, 58 691 27 15, 784 046 763, 601 642 339

biuro@ep-eq.pl • www.ep-eq.pl