



WPL201

Electric Pallet Truck 2.0T

- Smaller but stronger frame;
- New design visualized operation handle;
- Breakout traditional module design;
- 48V new control system & PMBM.

LION
TECHNOLOGY

EP EQUIPMENT CO.,LTD
www.ep-eq.eu



Electric Pallet Truck 2.0T

WPL201

Distinguishing mark				
1.1	Manufacturer			EP
1.2	Model designation			WPL201
1.3	Drive unit			Electrics
1.4	Operator type			Pedestrian
1.5	rated capacity	Q	kg	2000
1.6	Load center distance	c	mm	600
1.8	Load distance	x	mm	1000
1.9	Wheelbase	y	mm	1268
Weight				
2.1	Service weight (include battery)		kg	250
2.2	Axle loading, laden driving side/loading side		kg	685/1565
2.3	Axle loading, unladen driving side/loading side		kg	185/65
Types,Chassis				
3.1	Tyre type driving wheels/loading wheels			Polyurethane / Polyurethane
3.2	Tyre size, driving wheels (diameter×width)		mm	Φ245×94
3.3	Tyre size, loading wheels (diameter×width)		mm	2×Φ80x85/ Φ80×115
3.4	Tyre size, caster wheels (diameter×width)		mm	Φ74x48
3.5	Wheels, number driving, caster/loading (x=drive wheels)		mm	1× +2/4 / 1× +2/2
3.6	Track width, front,driving side	b10	mm	441
3.7	Track width,rear,loading side	b11	mm	370 / 515
Dimensions				
4.4	Lift height	h3	mm	140
4.9	Height drawbar in driving position min./max.	h14	mm	716 / 1240
4.15	Lowered height	h13	mm	82.5
4.19	Overall length	l1	mm	1592
4.20	Length to face of forks	l2	mm	423
4.21	Overall width	b1/ b2	mm	645 / 625
4.22	Fork dimensions	s/ e/ l	mm	55×170×1170
4.25	Distance between fork-arms	b5	mm	540 / 685
4.32	Ground clearance, center of wheelbase	m2	mm	27
4.34.1	Aisle width for pallets 1000 × 1200 crossways	Ast	mm	2228
4.34.2	Aisle width for pallets 800 × 1200 lengthways	Ast	mm	2076
4.35	Turning radius	Wa	mm	1428
Performance data				
5.1	Travel speed, laden/ unladen	km/ h	km/h	5 / 5.5
5.2	Lifting speed, laden/ unladen		m/ s	0.028 / 0.04
5.3	Lowering speed, laden/ unladen		m/ s	0.04 / 0.022
5.8	Max. gradeability, laden/unladen		%	6 / 16
5.10	Service brake type			Electromagnetic
Electric-engine				
6.1	Drive motor rating S2 60 min		kW	0.9
6.2	Lift motor rating at S3 15%		kW	0.84
6.3	The maximum allowed size battery		mm	245×160×380
6.4	Battery voltage/nominal capacity K5		V/ Ah	48/30 (Li-ion)
6.5	Battery weight		kg	14
Addition data				
8.1	Type of drive control			DC
10.5	Steering type			Mechanical
10.7	Sound pressure level at the driver's ear		dB (A)	74

If there are improvements of technical parameters or configurations, no further notice will be given.
The diagram shown may contain non-standard configurations.

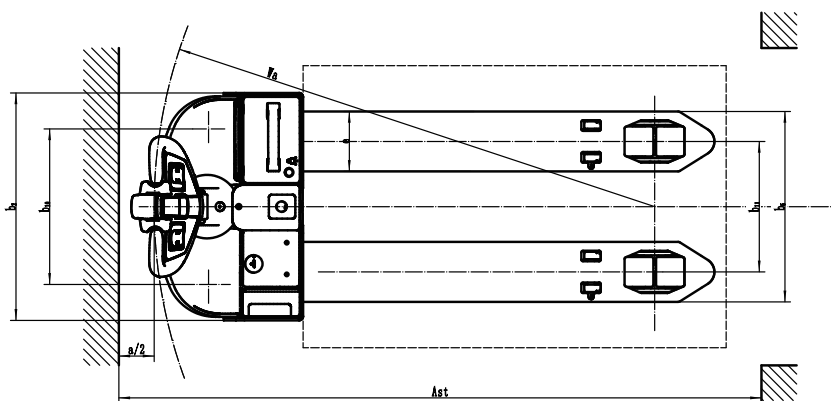
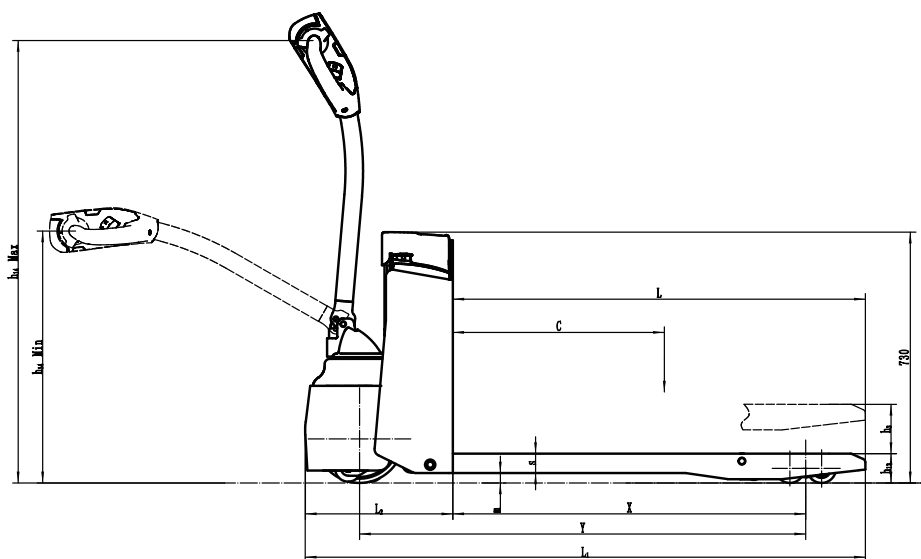

Option

No.	Optional items	WPL201
1.1	Fork dimension	<ul style="list-style-type: none"> ●685*1170 ○685*850、1000、1220、1300、1450、1600 ○540*850、1000、1170、1220、1300、1450、1600
1.3	Fork lowered height	●82.5
1.5	Fork carriage height	○1220mm (48in) ○1520mm (60in)
2.1	Load wheel type	●Double○Single
2.2	Load wheel material	●PU
2.3	Drive wheel material	●PU○Rubber
2.7	Battery capacity	●30Ah
2.8	Charger	●48V-15A integrated○48V-15A external
2.9	Battery indicator	●With time
2.15	Entry roller	●Yes and not customized (only for single load wheel)
3.2	Fork carriage	●No○According to fork dimensions
3.3	Castor wheels	●Yes and not customized
3.16	Turtle speed	●Yes and not customized
Note: ●standard ○option —NA		

WAELLER sp. z o.o. sp. k.

PL 83-034 Trąbki Wielkie, ul. Towarowa 1 • PL 80-457 Gdańsk, ul. Powstańców Wielkopolskich 11
 Tel. (+48) 58 683 01 53, 58 691 27 15, 784 046 763, 601 642 339

biuro@ep-eq.pl • www.ep-eq.pl